

April 2023

## Material Handling and Storage Best Practices

Nucor Building Systems recommends the following material handling and storage best practices in accordance with the Metal Building Manufacturers Association (MBMA). Please reference the following document.

### Material Receiving and Claims

This building is designed, manufactured, and delivered in accordance with most recent addition of the M.B.M.A. metal building systems manual. Consult the information in the “common industry practices” section. Metal building supplier (MBS) is not responsible for carrier damage or damage resulting from improper storage.

- Check shipment against delivery tickets during unloading. Note any damage or discrepancies on the delivery tickets before signing as receiver. Pictures and such notes must be reported to MBS immediately.
- Customer assumes full responsibility for the condition of this material after delivery by the trucking company.
- MBS is not responsible for items accepted in questionable condition.
- Upon acceptance of shipment(s), the contractor is responsible for the proper storage and handling of materials as described in MBS’s documentation.
- MBS is not responsible for injury, damage, or loss as a result of improper storage and/or handling.
- All claims must be filed with MBS’s quality services representative prior to any field modifications or purchases that may result in a charge to MBS.

### Material Handling

Caution must be taken with unloading and handling materials on site. The metal building supplier (MBS) is not responsible for damage caused by mishandling or storage of materials.

- Panel bundles over 25’ long should be handled with the use of a spreader bar and nylon straps. Lifting should occur at the center of gravity. This is critical to prevent damage to the materials.
- Panel bundles and crates less than 25’ long can be handled with forks provided the forks are a minimum of 5’ apart.
- Steel chokers, cables or chains are not recommended due to potential damage to crates/bundles and scraping of primer on structural members.

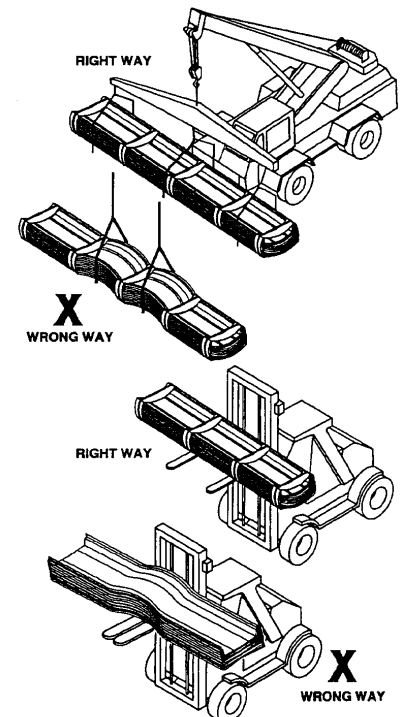

## Material Storage

Prolonged storage of materials in a bundle is **NOT RECOMMENDED**. Materials should be erected / installed shortly after delivery if possible or stored in manner to protect them from the elements.

- If conditions do not permit immediate installation, extra care should be taken to protect materials from red rust, white rust, or water marks.
  - Reference to bundled/crated materials include sheeting goods as well secondary member or other materials that may be bundled or crated. MBS cannot be liable for improper storage.
- If moisture penetrates between materials, they should be removed from the bundles and allowed to dry. Failure to do so has a high risk of causing damage.
- Store bundled/crated material off the ground sufficiently high to allow air circulation beneath the bundle/crate and to prevent rising water from entering the bundle/crate. Also, elevate one end of the bundle/crate to enable proper drainage. **See Figure 1**
- Prevent rain from entering bundle/crate by covering with a tarp and make provisions for air circulation between draped edges of the tarp and ground. Failure to allow for air circulation could result in excessive moisture/condensation and cause panel damage. See Figure 1
- Structural members are also susceptible to corrosion and damage from prolonged storage; therefore, similar care should be taken. Members should be stored to allow drainage through weep holes located in the parts. **See Figure 2**

## Material Storage

**Figure 1:**

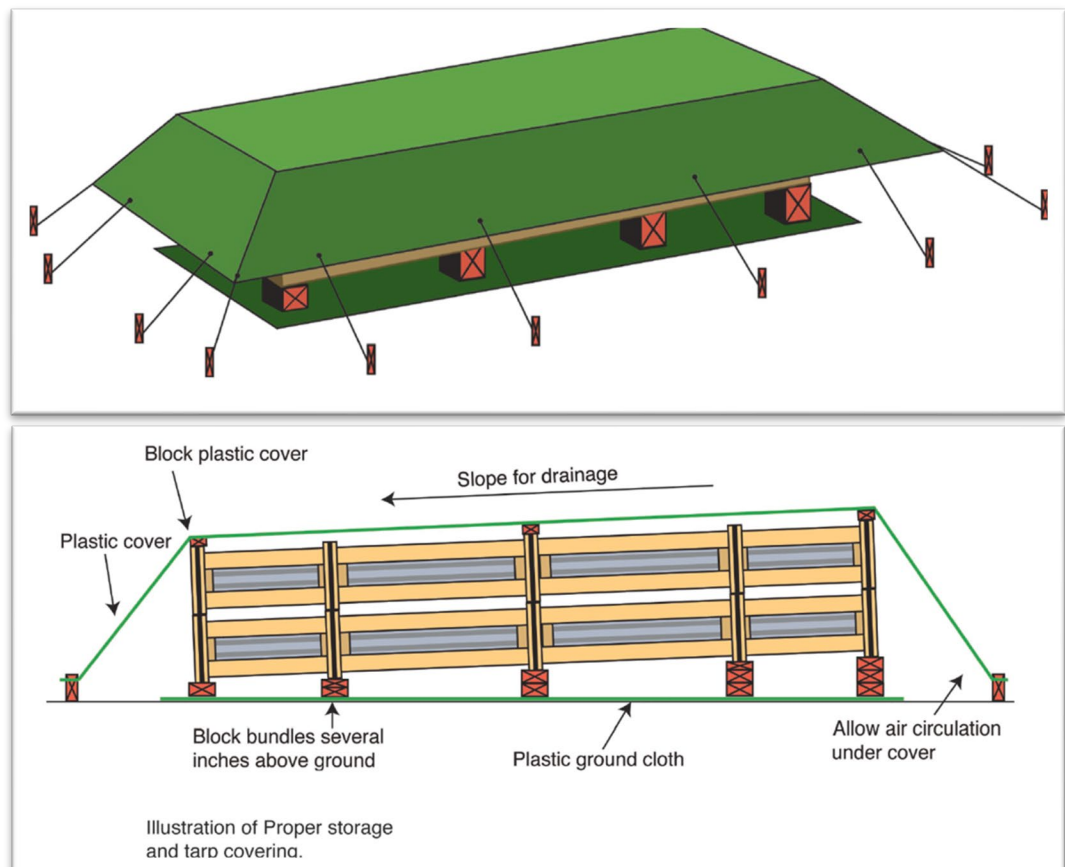

**Figure 2:**

