



# PRODUCT & ENGINEERING MANUAL

## HR3 INSULATED ROOF PANEL TABLE OF CONTENTS

HR3 Insulated Roof System.....	2
HR3 Insulated Roof System Span Tables .....	3
2-1/2" Panel Thickness – Standard (1) Fastener .....	3
2-1/2" Panel Thickness – Optional (2) Fasteners .....	4
4" Panel Thickness – Standard (1) Fastener.....	5
4" Panel Thickness – Optional (2) Fasteners .....	6
5" Panel Thickness – Standard (1) Fastener.....	7
5" Panel Thickness – Optional (2) Fasteners .....	8
6" Panel Thickness – Standard (1) Fastener.....	9
6" Panel Thickness – Optional (2) Fasteners .....	10
Standard Details .....	11
ED4310PE - Horizontal Gutter .....	11
EH4006 - High Eave Sculptured .....	12
EI4010 - High Eave Parapet .....	13
EG4010 - Standard Ridge.....	14
EG2100PE - Field Fabricated Metal Peak Box .....	15
EA4021 - End Lap .....	16



## HR3 INSULATED ROOF SYSTEM

The HR3 insulated high rib roof system panel is available as a component of one of Nucor Building Systems' Standard Roof Systems.

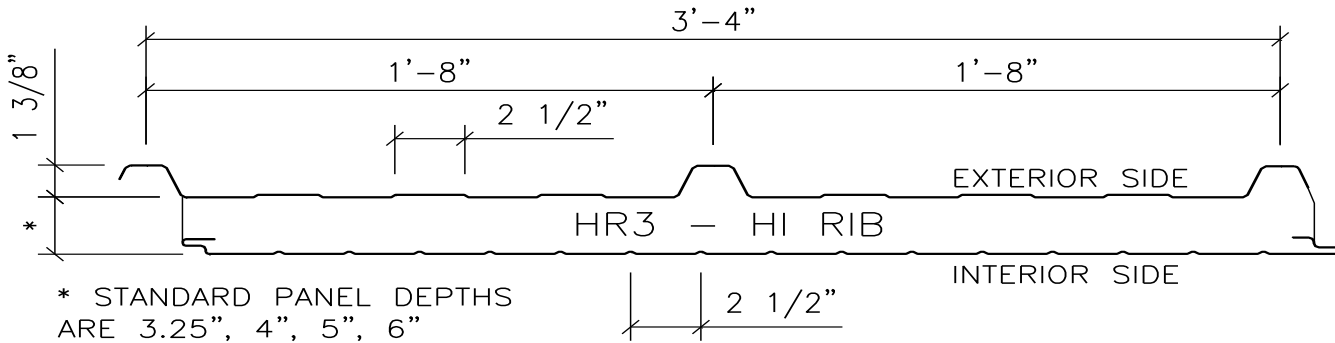

Information about the available panel thickness options, R and U factors, exterior and interior colors and finishes, available panel lengths, performance and testing information, and much more is available at the Nucor Building Systems website at the below link.

[HR3 Insulated High Rib Roof Panel](#)

The following pages outline span capacities for a typical panel configuration as well as provide Nucor standard details for this roof system.



# PRODUCT & ENGINEERING MANUAL

## HR3 INSULATED ROOF SYSTEM SPAN TABLES

### 2-1/2" PANEL THICKNESS – STANDARD (1) FASTENER

2-1/2" SR2 Insulated Standing Seam Roof Panel – 26 Gauge Exterior/Interior – 1 Fastener per Panel Rib									
2 Equal Spans									
Span (ft.)	Gravity (psf)	Deflection L/240	Uplift Capacity (psf) per Support Thickness						
			0.060	0.067	0.075	0.089	0.099	0.105	0.120
4	83	n/c	35	40	45	59	69	75	83
4.5	73	n/c	31	35	40	52	61	66	73
5	65	n/c	28	32	36	47	55	60	65
5.5	59	n/c	25	29	33	43	50	54	59
6	54	n/c	23	26	30	39	46	50	54
7	45	n/c	20	22	26	33	39	42	45
3 Equal Spans									
Span (ft.)	Gravity (psf)	Deflection L/240	Uplift Capacity (psf) per Support Thickness						
			0.060	0.067	0.075	0.089	0.099	0.105	0.120
4	83	n/c	40	45	52	67	78	83	83
4.5	73	n/c	35	40	46	60	69	73	73
5	65	n/c	32	36	41	54	62	65	65
5.5	59	n/c	29	33	37	49	57	59	59
6	54	n/c	26	30	34	45	52	54	54
7	45	n/c	22	26	29	38	44	45	45

Insulated roof panel deflections are held to L/240. Contact the engineering team for minimum panel lengths, span capacities with different exterior or interior panel thicknesses, or fastener configurations.



# PRODUCT & ENGINEERING MANUAL

## 2-1/2" PANEL THICKNESS – OPTIONAL (2) FASTENERS

2-1/2" SR2 Insulated Standing Seam Roof Panel – 26 Gauge Exterior/Interior – 2 Fasteners per Panel Rib									
2 Equal Spans									
Span (ft.)	Gravity (psf)	Deflection L/240	Uplift Capacity (psf) per Support Thickness						
			0.060	0.067	0.075	0.089	0.099	0.105	0.120
4	83	n/c	70	80	83	83	83	83	83
4.5	73	n/c	62	71	73	73	73	73	73
5	65	n/c	56	64	65	65	65	65	65
5.5	59	n/c	51	58	59	59	59	59	59
6	54	n/c	46	53	54	54	54	54	54
7	45	n/c	40	45	45	45	45	45	45
3 Equal Spans									
Span (ft.)	Gravity (psf)	Deflection L/240	Uplift Capacity (psf) per Support Thickness						
			0.060	0.067	0.075	0.089	0.099	0.105	0.120
4	83	n/c	80	83	83	83	83	83	83
4.5	73	n/c	71	73	73	73	73	73	73
5	65	n/c	64	65	65	65	65	65	65
5.5	59	n/c	58	59	59	59	59	59	59
6	54	n/c	53	54	54	54	54	54	54
7	45	n/c	45	45	45	45	45	45	45

Insulated roof panel deflections are held to L/240. Contact the engineering team for minimum panel lengths, span capacities with different exterior or interior panel thicknesses, or fastener configurations.



# PRODUCT & ENGINEERING MANUAL

## 4" PANEL THICKNESS – STANDARD (1) FASTENER

4" SR2 Insulated Standing Seam Roof Panel – 26 Gauge Exterior/Interior – 1 Fastener per Panel Rib									
2 Equal Spans									
Span (ft.)	Gravity (psf)	Deflection L/240	Uplift Capacity (psf) per Support Thickness						
			0.060	0.067	0.075	0.089	0.099	0.105	0.120
4	116	n/c	35	40	45	59	69	75	94
4.5	102	n/c	31	35	40	52	61	66	84
5	90	n/c	28	32	36	47	55	60	75
5.5	81	n/c	25	29	33	43	50	54	68
6	73	n/c	23	26	30	39	46	50	63
7	61	n/c	20	22	26	33	39	42	54
3 Equal Spans									
Span (ft.)	Gravity (psf)	Deflection L/240	Uplift Capacity (psf) per Support Thickness						
			0.060	0.067	0.075	0.089	0.099	0.105	0.120
4	116	n/c	40	45	52	67	78	85	107
4.5	102	n/c	35	40	46	60	69	75	95
5	90	n/c	32	36	41	54	62	68	85
5.5	81	n/c	29	33	37	49	57	62	78
6	73	n/c	26	30	34	45	52	56	71
7	61	n/c	22	26	29	38	44	48	61

Insulated roof panel deflections are held to L/240. Contact the engineering team for minimum panel lengths, span capacities with different exterior or interior panel thicknesses, or fastener configurations.



# PRODUCT & ENGINEERING MANUAL

## **4" PANEL THICKNESS – OPTIONAL (2) FASTENERS**

<b>4" SR2 Insulated Standing Seam Roof Panel – 26 Gauge Exterior/Interior – 2 Fasteners per Panel Rib</b>									
<b>2 Equal Spans</b>									
Span (ft.)	Gravity (psf)	Deflection L/240	Uplift Capacity (psf) per Support Thickness						
			0.060	0.067	0.075	0.089	0.099	0.105	0.120
4	116	n/c	70	80	91	116	116	116	116
4.5	102	n/c	62	71	81	102	102	102	102
5	90	n/c	56	64	73	90	90	90	90
5.5	81	n/c	51	58	66	81	81	81	81
6	73	n/c	46	53	61	73	73	73	73
7	61	n/c	40	45	52	61	61	61	61
<b>3 Equal Spans</b>									
Span (ft.)	Gravity (psf)	Deflection L/240	Uplift Capacity (psf) per Support Thickness						
			0.060	0.067	0.075	0.089	0.099	0.105	0.120
4	116	n/c	80	91	104	116	116	116	116
4.5	102	n/c	71	81	92	102	102	102	102
5	90	n/c	64	72	83	90	90	90	90
5.5	81	n/c	58	66	75	81	81	81	81
6	73	n/c	53	60	69	73	73	73	73
7	61	n/c	45	52	59	61	61	61	61

Insulated roof panel deflections are held to L/240. Contact the engineering team for minimum panel lengths, span capacities with different exterior or interior panel thicknesses, or fastener configurations.



# PRODUCT & ENGINEERING MANUAL

## 5" PANEL THICKNESS – STANDARD (1) FASTENER

5" SR2 Insulated Standing Seam Roof Panel – 26 Gauge Exterior/Interior – 1 Fastener per Panel Rib									
2 Equal Spans									
Span (ft.)	Gravity (psf)	Deflection L/240	Uplift Capacity (psf) per Support Thickness						
			0.060	0.067	0.075	0.089	0.099	0.105	0.120
4	146	n/c	35	40	45	59	69	75	94
4.5	128	n/c	31	35	40	52	61	66	84
5	114	n/c	28	32	36	47	55	60	75
5.5	102	n/c	25	29	33	43	50	54	68
6	93	n/c	23	26	30	39	46	50	63
7	77	n/c	20	22	26	33	39	42	54
3 Equal Spans									
Span (ft.)	Gravity (psf)	Deflection L/240	Uplift Capacity (psf) per Support Thickness						
			0.060	0.067	0.075	0.089	0.099	0.105	0.120
4	146	n/c	40	45	52	67	78	85	107
4.5	128	n/c	35	40	46	60	69	75	95
5	114	n/c	32	36	41	54	62	68	85
5.5	102	n/c	29	33	37	49	57	62	78
6	93	n/c	26	30	34	45	52	56	71
7	77	n/c	22	26	29	38	44	48	61

Insulated roof panel deflections are held to L/240. Contact the engineering team for minimum panel lengths, span capacities with different exterior or interior panel thicknesses, or fastener configurations.





# PRODUCT & ENGINEERING MANUAL

## **5" PANEL THICKNESS – OPTIONAL (2) FASTENERS**

<b>5" SR2 Insulated Standing Seam Roof Panel – 26 Gauge Exterior/Interior – 2 Fasteners per Panel Rib</b>									
<b>2 Equal Spans</b>									
Span (ft.)	Gravity (psf)	Deflection L/240	Uplift Capacity (psf) per Support Thickness						
			0.060	0.067	0.075	0.089	0.099	0.105	0.120
4	146	n/c	70	80	91	118	138	146	146
4.5	128	n/c	62	71	81	105	123	128	128
5	114	n/c	56	64	73	95	110	114	114
5.5	102	n/c	51	58	66	86	100	102	102
6	93	n/c	46	53	61	79	92	93	93
7	77	n/c	40	45	52	67	77	77	77
<b>3 Equal Spans</b>									
Span (ft.)	Gravity (psf)	Deflection L/240	Uplift Capacity (psf) per Support Thickness						
			0.060	0.067	0.075	0.089	0.099	0.105	0.120
4	146	n/c	80	91	104	135	146	146	146
4.5	128	n/c	71	81	92	120	128	128	128
5	114	n/c	64	72	83	108	114	114	114
5.5	102	n/c	58	66	75	98	102	102	102
6	93	n/c	53	60	69	90	93	93	93
7	77	n/c	45	52	59	77	77	77	77

Insulated roof panel deflections are held to L/240. Contact the engineering team for minimum panel lengths, span capacities with different exterior or interior panel thicknesses, or fastener configurations.





# PRODUCT & ENGINEERING MANUAL

## **6" PANEL THICKNESS – STANDARD (1) FASTENER**

<b>6" SR2 Insulated Standing Seam Roof Panel – 26 Gauge Exterior/Interior – 1 Fastener per Panel Rib</b>									
<b>2 Equal Spans</b>									
Span (ft.)	Gravity (psf)	Deflection L/240	Uplift Capacity (psf) per Support Thickness						
			0.060	0.067	0.075	0.089	0.099	0.105	0.120
4	175	n/c	35	40	45	59	69	75	94
4.5	155	n/c	31	35	40	52	61	66	84
5	138	n/c	28	32	36	47	55	60	75
5.5	124	n/c	25	29	33	43	50	54	68
6	112	n/c	23	26	30	39	46	50	63
7	94	n/c	20	22	26	33	39	42	54
<b>3 Equal Spans</b>									
Span (ft.)	Gravity (psf)	Deflection L/240	Uplift Capacity (psf) per Support Thickness						
			0.060	0.067	0.075	0.089	0.099	0.105	0.120
4	175	n/c	40	45	52	67	78	85	107
4.5	155	n/c	35	40	46	60	69	75	95
5	138	n/c	32	36	41	54	62	68	85
5.5	124	n/c	29	33	37	49	57	62	78
6	112	n/c	26	30	34	45	52	56	71
7	94	n/c	22	26	29	38	44	48	61

Insulated roof panel deflections are held to L/240. Contact the engineering team for minimum panel lengths, span capacities with different exterior or interior panel thicknesses, or fastener configurations.



# PRODUCT & ENGINEERING MANUAL

## 6" PANEL THICKNESS – OPTIONAL (2) FASTENERS

6" SR2 Insulated Standing Seam Roof Panel – 26 Gauge Exterior/Interior – 2 Fasteners per Panel Rib									
2 Equal Spans									
Span (ft.)	Gravity (psf)	Deflection L/240	Uplift Capacity (psf) per Support Thickness						
			0.060	0.067	0.075	0.089	0.099	0.105	0.120
4	175	n/c	70	80	91	118	138	150	175
4.5	155	n/c	62	71	81	105	123	133	155
5	138	n/c	56	64	73	95	110	120	138
5.5	124	n/c	51	58	66	86	100	109	124
6	112	n/c	46	53	61	79	92	100	112
7	94	n/c	40	45	52	67	79	85	94
3 Equal Spans									
Span (ft.)	Gravity (psf)	Deflection L/240	Uplift Capacity (psf) per Support Thickness						
			0.060	0.067	0.075	0.089	0.099	0.105	0.120
4	175	n/c	80	91	104	135	157	170	175
4.5	155	n/c	71	81	92	120	139	151	155
5	138	n/c	64	72	83	108	125	136	138
5.5	124	n/c	58	66	75	98	114	124	124
6	112	n/c	53	60	69	90	104	112	112
7	94	n/c	45	52	59	77	89	94	94

Insulated roof panel deflections are held to L/240. Contact the engineering team for minimum panel lengths, span capacities with different exterior or interior panel thicknesses, or fastener configurations.



# PRODUCT & ENGINEERING MANUAL

## STANDARD DETAILS

### ED4310PE - HORIZONTAL GUTTER

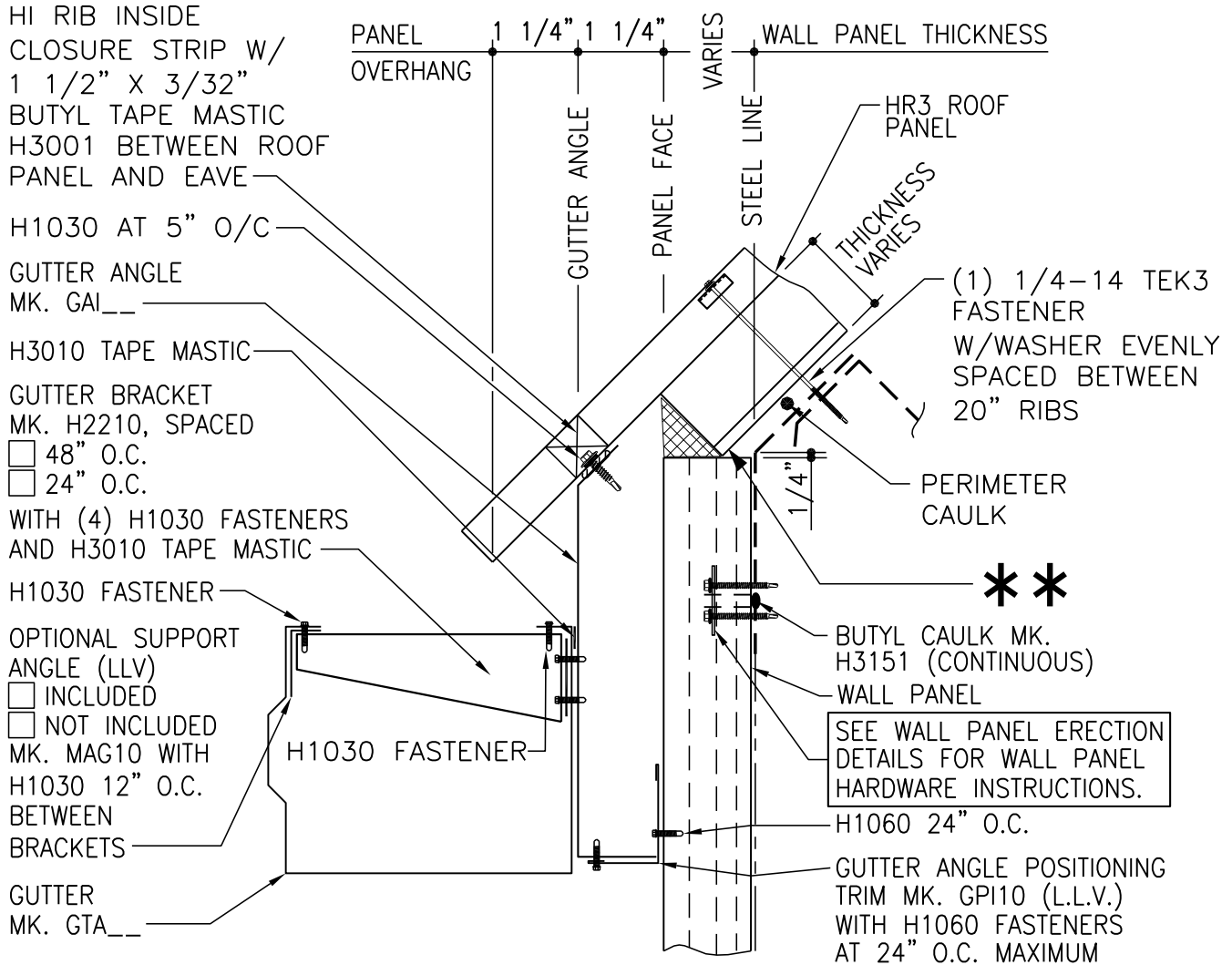

## HR3 HORIZONTAL GUTTER

**ED4310**

\*\*

= PANEL NOTCH WILL NOT LINE UP WITH EAVE LINE. THIS POINT WILL VARY DEPENDING ON THE ROOF SLOPE AND THICKNESS OF PANEL.

ED4310

- Horizontal gutter is provided as the standard.

LAST REVISION  
DATE: 02/16/15  
BY: AK CHK: EGB

DETAIL NAME IF APPLICABLE  
[ED4310PE.dwg](#)

6.6.11



# PRODUCT & ENGINEERING MANUAL

## EH4006 - HIGH EAVE SCULPTURED

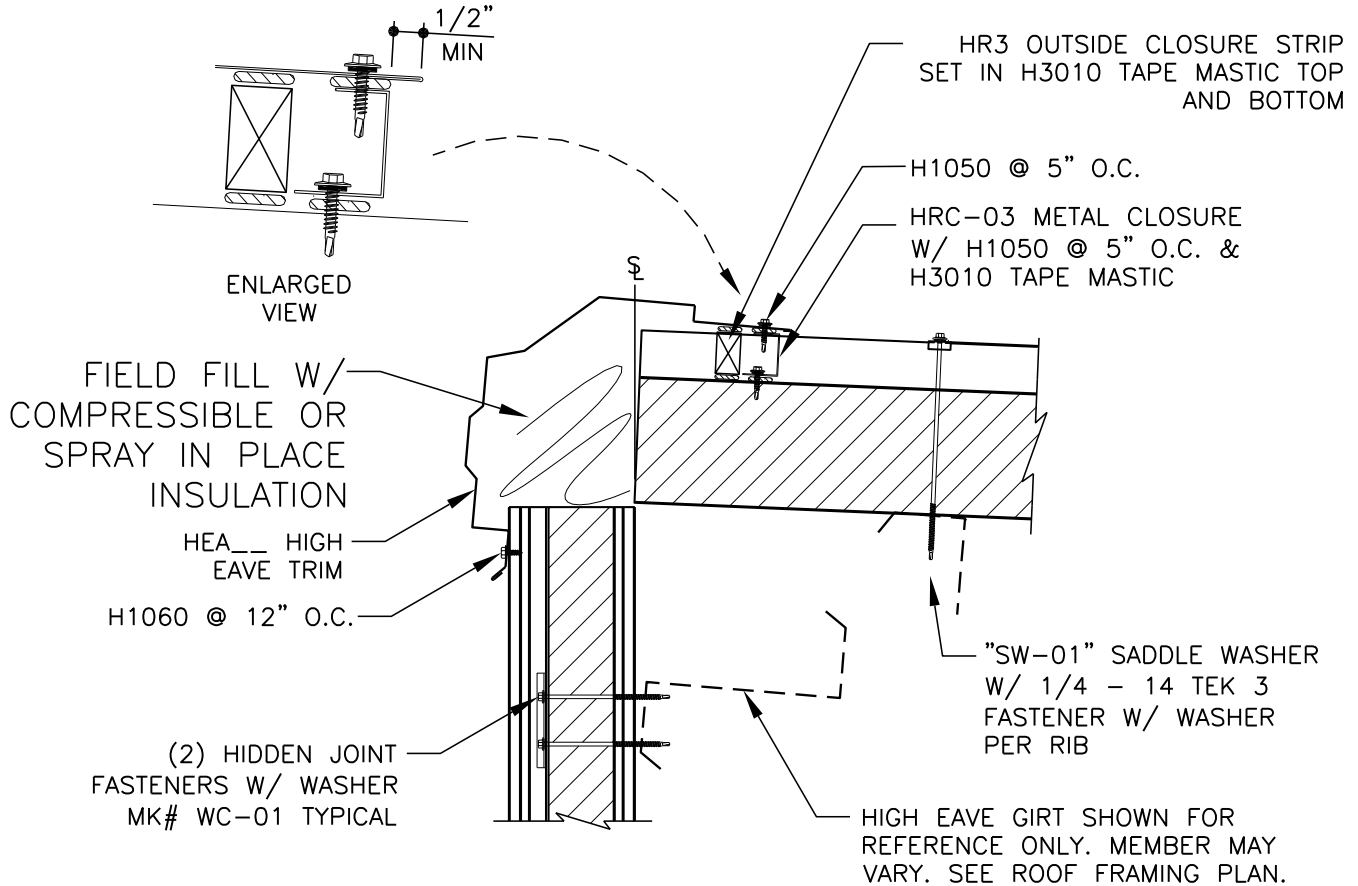

PANEL THICKNESS	HIDDEN FASTENER
2"	#14 X 2 SDHH
2 1/2"	#14 X 3 SDHH
3"	#14 X 3 SDHH
4"	#14 X 4 SDHH

## HIGH SIDE EAVE

HR3 INSULATED ROOF PANEL  
SEE INSULATED WALL PANEL ERECTION NOTES FOR ASSEMBLY METHOD

**EH4006**

- The profile of the high eave sculptured trim matches the profile of the sculptured rake trim so that they can be mitered together.

LAST REVISION  
DATE: 02/16/15  
BY: AK CHK: EGB

DETAIL NAME IF APPLICABLE  
[EH4006.dwg](#)

6.6.12



# PRODUCT & ENGINEERING MANUAL

## EI4010 - HIGH EAVE PARAPET

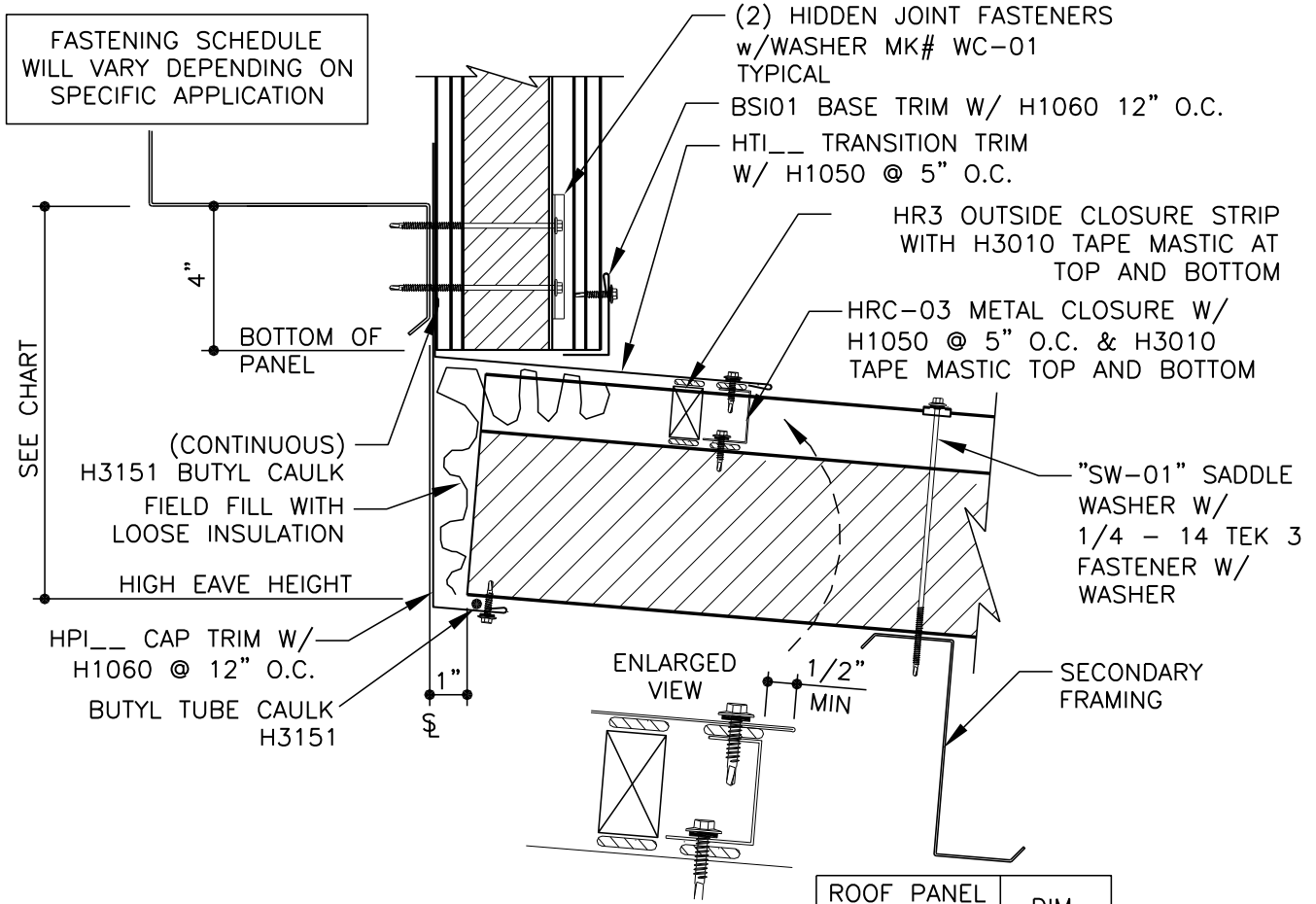

PANEL THICKNESS	HIDDEN FASTENER
2"	#14 X 2 SDHH
2 1/2"	#14 X 3 SDHH
3"	#14 X 3 SDHH
4"	#14 X 4 SDHH

ROOF PANEL THICKNESS	DIM.
2 1/2"	0'-8"
4"	9 1/2"
5"	10 1/2"
6"	11 1/2"

## HIGH EAVE PARAPET DETAIL

HR3 INSULATED PANEL

**EI4010**

LAST REVISION  
DATE: 02/16/15  
BY: AK CHK: EGB

DETAIL NAME IF APPLICABLE  
**EI4010.dwg**

6.6.13



# PRODUCT & ENGINEERING MANUAL

## EG4010 - STANDARD RIDGE

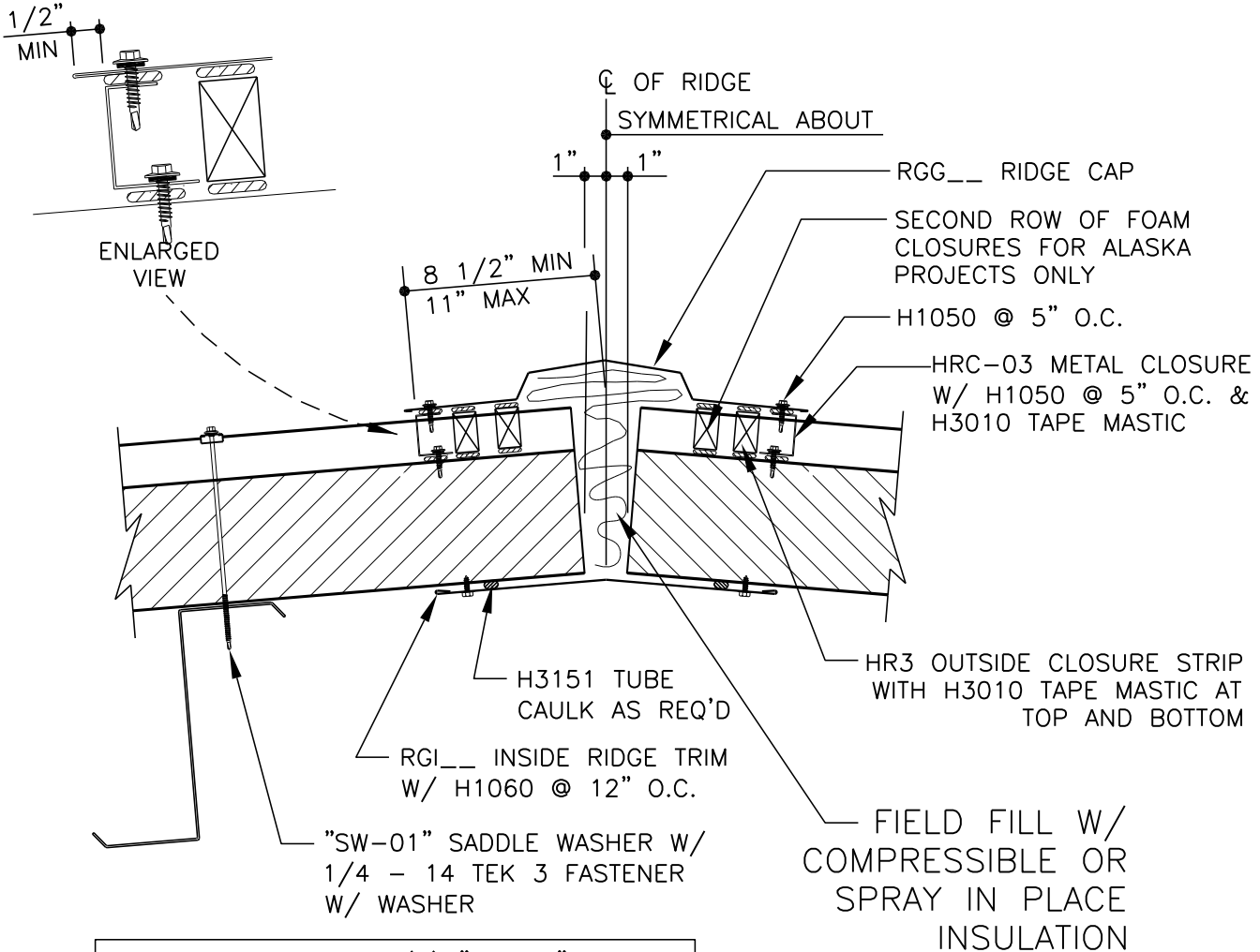

NOTE: FIELD LOCATE (1) "SW-01" SADDLE WASHER CLIP ASSEMBLY AT EVERY HIGH RIB.

## RIDGE DETAIL

HR3 INSULATED PANEL

**EG4010**

- The ridge cap is the same as the CFR low profile ridge cap.

LAST REVISION  
DATE: 02/16/15  
BY: AK CHK: EGB

DETAIL NAME IF APPLICABLE  
[EG4010.dwg](#)

6.6.14





# PRODUCT & ENGINEERING MANUAL

## EG2100PE - FIELD FABRICATED METAL PEAK BOX

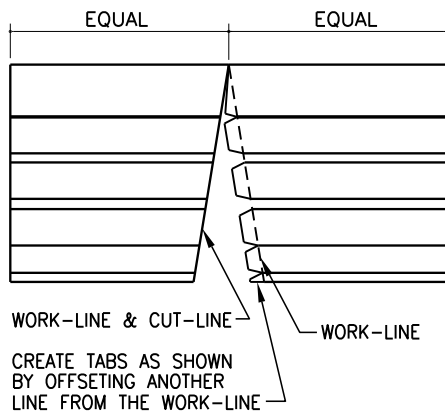

**IMPORTANT NOTE**  
DO NOT ATTACH THE PEAK BOX TO THE RAKE TRIM OR THE ROOF PANEL. THE RAKE TRIM MUST BE ALLOWED TO FLOAT WITH THERMAL EXPANSION AND CONTRACTION, SEPARATE FROM THE PEAK BOX.  
SEE THE ROOF SHEETING ERECTION MANUAL FOR ADDITIONAL PARTS REQUIRED AT THIS LOCATION.

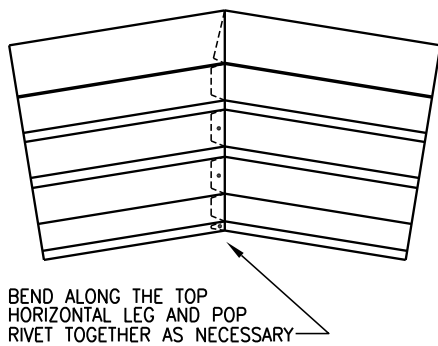

FRONT VIEWS  
OF ASSEMBLY PROCESS

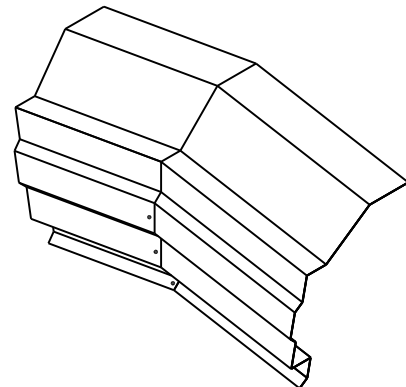

ISOMETRIC VIEWS  
OF FINISHED ASSEMBLY

### FIELD-FABRICATED PEAK BOX INSTRUCTIONS

- The customer has the option of purchasing the metal peak boxes or field fabricating a metal peak box out of a piece of standard rake trim.
- The standard metal peak boxes work up through 6:12 roof slope, and only available in white.
- The standard CAD detail for the field fabricated metal peak box shows a lot more information on how to fabricate this.
- The metal peak box, as shown in the detail, allows the rake trim to slide as it is designed to. Field mitering the rake trim together at the peak with sliding clips is not recommended.
- It takes anywhere from 30-60 minutes to field fabricate one of these metal beak boxes.





# PRODUCT & ENGINEERING MANUAL

## EA4021 - END LAP

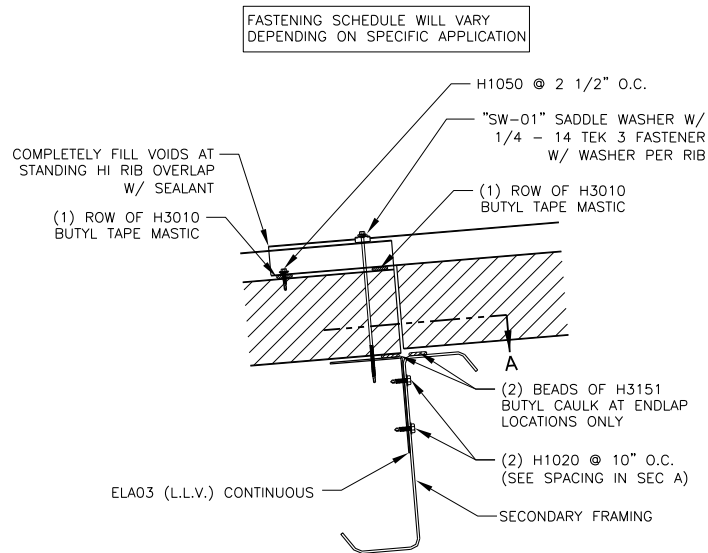

ERECTOR NOTE: FIELD DRILL/NOTCH LAP ANGLE AT PURLIN LAP BOLTS AND PURLIN BRACING AS REQUIRED

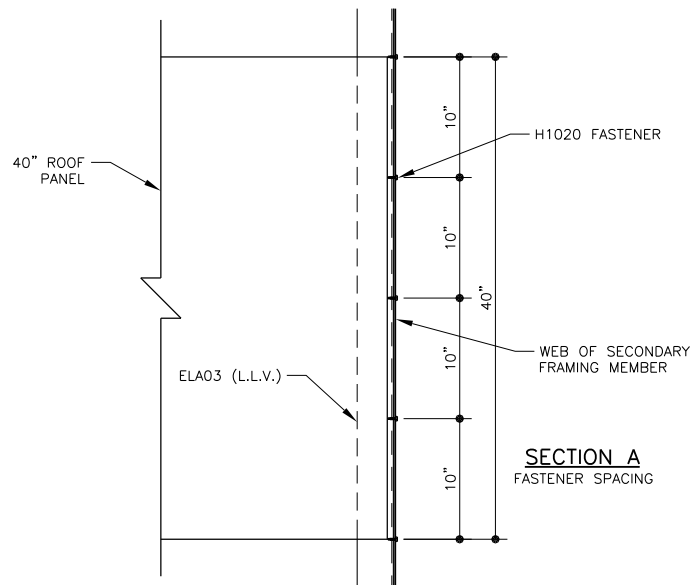

### HR3 INSULATED PANEL ENDLAP

HR3 INSULATED PANEL

EA4021

- Insulation and interior metal skin is removed from portion of exterior skin that will be lapped onto the lower panel.

LAST REVISION  
DATE: 02/16/15  
BY: AK CHK: EGB

DETAIL NAME IF APPLICABLE

[EA4021.dwg](#)

6.6.16