



PRODUCT & ENGINEERING MANUAL

THROUGH-FASTENED ROOF/WALL PANEL SYSTEMS TABLE OF CONTENTS

Nucor Roof and Wall Sheeting Perspective	2
Nucor Classic Roof™ System	3
Nucor Classic Roof™ Property and Span Tables	4
Nucor Wall Systems	5
Nucor Classic wall™ Property and Span Tables	6
Nucor Reverse Classic wall™ Property and Span Tables	7
Nucor Accent wall™ Property and Span Tables	8



PRODUCT & ENGINEERING MANUAL

NUCOR ROOF AND WALL SHEETING PERSPECTIVE

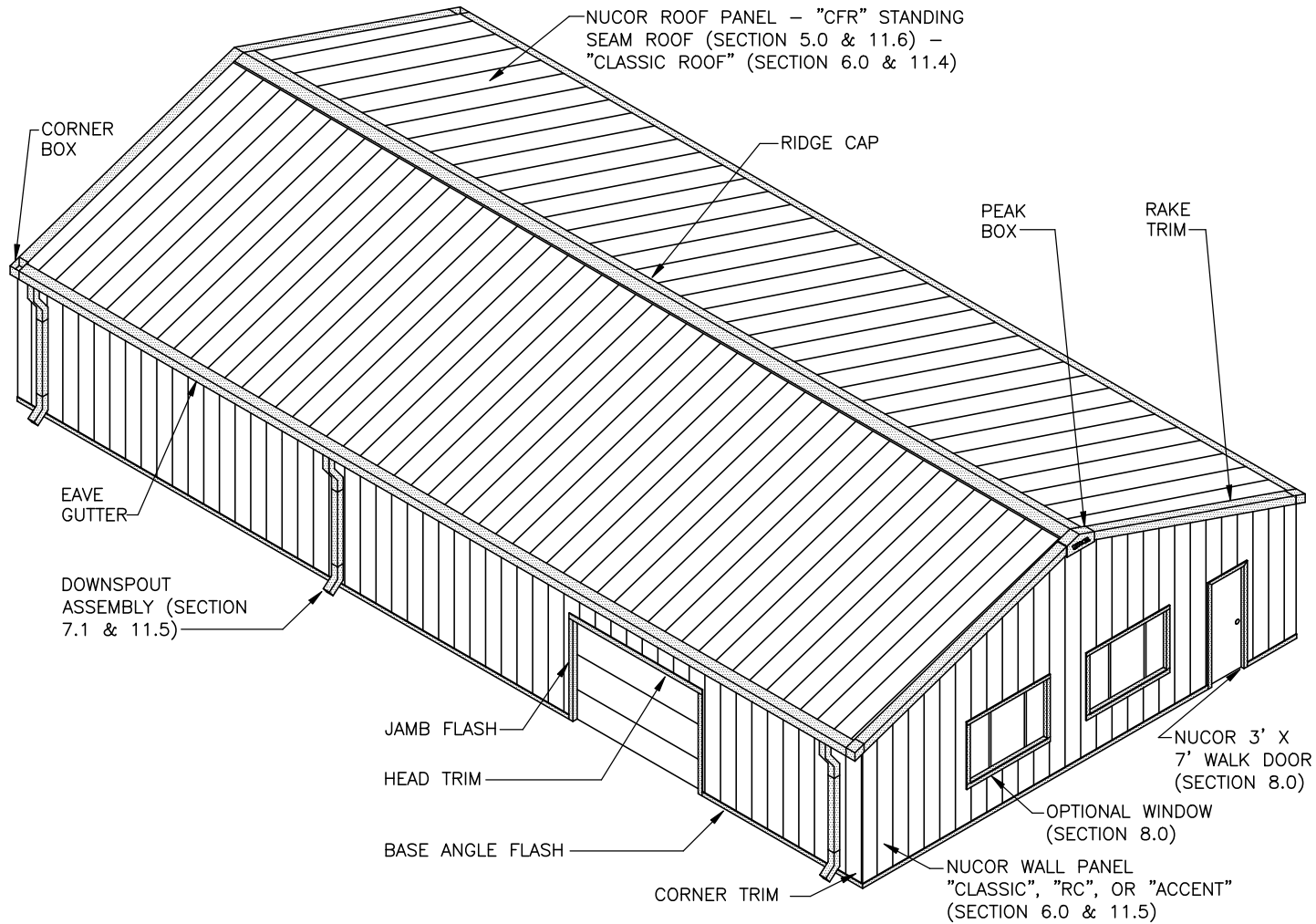

LAST REVISION
DATE: 04/11/02
BY: CDM CHK: RJF

DETAIL NAME IF APPLICABLE
SH0010PE.DWG

6.0.2



NUCOR CLASSIC ROOF™ SYSTEM

The Nucor Classic Roof™ through-fastened roof system panel is available as a component of one of Nucor Building Systems' Standard Roof Systems.

The standard Nucor Classic Roof™ System has a purlin bearing leg

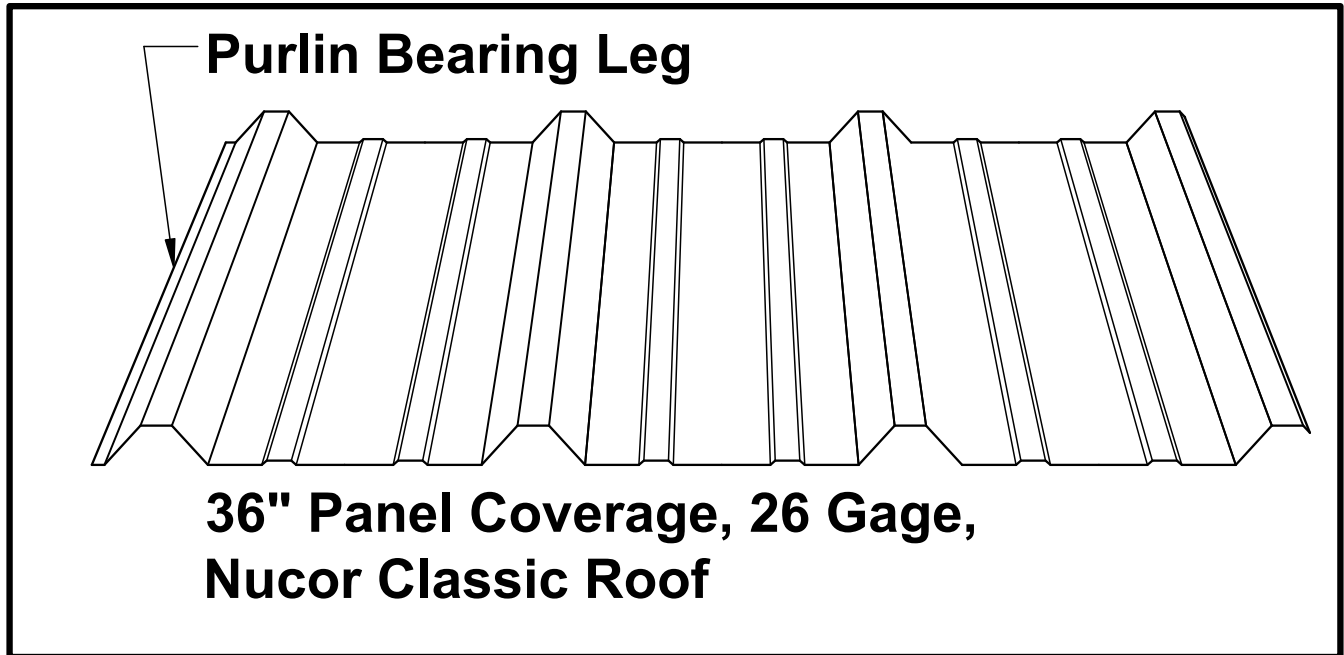

Information about the available panel finishes, installation manuals, erection details, performance and testing information, and much more is available at the Nucor Building Systems website at the below link.

[Nucor Classic Roof™ Panel](#)

The following page outlines the span capacities for the Nucor Classic Roof™ Panel.



PRODUCT & ENGINEERING MANUAL

NUCOR CLASSIC ROOF™ PROPERTY AND SPAN TABLES

Nucor Classic Roof™ Panel 26 - Gage: Fy = 50 ksi									
Panel Material Information					Panel Properties per foot of panel width				
Panel Gage	Thickness (in.)	Yield (Ksi)	Tensile (Ksi)	Panel Wt. (Psf)	Top in Compression			Bottom in Compression	
					Ix (Gross) (in ⁴)	Sx (eff.) (in ³)	Ma (Kip-in.)	Sx (eff.) (in ³)	Ma (Kip-in.)
26	0.0177	50	58	0.86	0.0493	0.040	1.2040	0.047	1.4017

Gravity Loading and Wind Pressure (psf): Panel: (Stress, Deflection, and Web Crippling)

Span (Ft)	Simple Span			2 Equal Spans			3 Equal Spans		
	Stress	Deflection		Stress	Deflection		Stress	Deflection	
		L/60	L/240		L/60	L/240		L/60	L/240
2.0	152	n/c	n/c	116	n/c	n/c	116	n/c	n/c
2.5	121	n/c	n/c	93	n/c	n/c	93	n/c	n/c
3.0	92	n/c	n/c	77	n/c	n/c	77	n/c	n/c
3.5	67	n/c	n/c	66	n/c	n/c	66	n/c	n/c
4.0	52	n/c	n/c	58	n/c	n/c	58	n/c	n/c
4.5	41	n/c	37	48	n/c	n/c	52	n/c	n/c
5.0	33	n/c	27	38	n/c	n/c	46	n/c	n/c

Wind Suction (psf): Panel: (Stress and Deflection)

Span (Ft)	Simple Span			2 Equal Spans			3 Equal Spans		
	Stress	Deflection		Stress	Deflection		Stress	Deflection	
		L/60	L/240		L/60	L/240		L/60	L/240
2.0	241	n/c	n/c	241	n/c	n/c	258	n/c	n/c
2.5	154	n/c	n/c	154	n/c	n/c	165	n/c	n/c
3.0	107	n/c	n/c	107	n/c	n/c	115	n/c	n/c
3.5	79	n/c	78	79	n/c	n/c	84	n/c	n/c
4.0	60	n/c	52	60	n/c	n/c	65	n/c	n/c
4.5	48	n/c	37	48	n/c	n/c	51	n/c	n/c
5.0	38	n/c	27	38	n/c	n/c	41	n/c	n/c

Wind Suction (psf): Fasteners: (Pull-out, Pull-Over, and Tensile Failure)

Span (Ft)	Purlin Thickness						
	0.060	0.067	0.075	0.089	0.099	0.105	0.120
2.0	105	105	105	105	105	105	105
2.5	84	84	84	84	84	84	84
3.0	70	70	70	70	70	70	70
3.5	60	60	60	60	60	60	60
4.0	53	53	53	53	53	53	53
4.5	47	47	47	47	47	47	47
5.0	42	42	42	42	42	42	42

n/c = value does not control (i.e. value is greater than controlling stress value)

Contact the engineering team for capacities with different panel or fastener configurations.

LAST REVISION
 DATE: 03/11/15
 BY: AAJ CHK: MDK



NUCOR WALL SYSTEMS

Nucor standard wall panels are available as components of one of Nucor Building Systems' Standard Wall Systems.

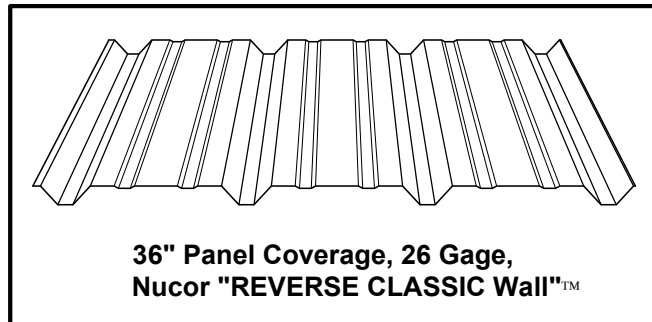
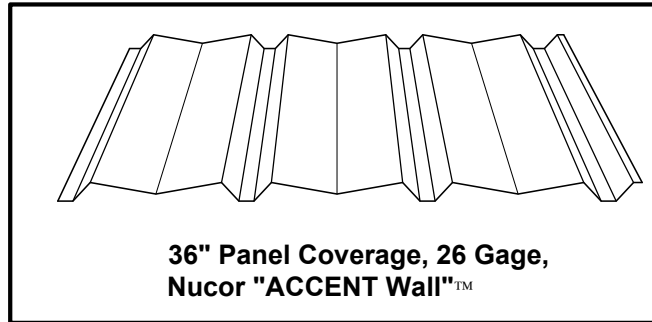
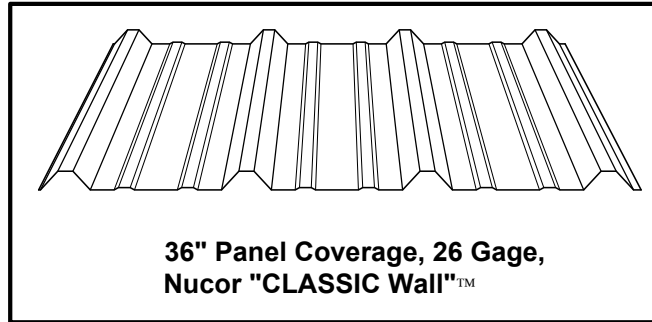

Information about the available panel finishes and erection details is available at the Nucor Building Systems website at the below link.

[Nucor Wall System Panels](#)

The following page outlines the span capacities for the Nucor standard wall panel profiles.



PRODUCT & ENGINEERING MANUAL

NUCOR CLASSIC WALL™ PROPERTY AND SPAN TABLES

Nucor Classic Wall™ Panel - 26 Gage: Fy = 50 ksi									
Panel Material Information					Panel Properties per foot of panel width				
Panel Gage	Thickness (in.)	Yield (Ksi)	Tensile (Ksi)	Panel Wt. (Psf)	Top in Compression			Bottom in Compression	
					Ix (Gross) (in ⁴)	Sx (eff.) (in ³)	Ma (Kip-in.)	Sx (eff.) (in ³)	Ma (Kip-in.)
26	0.0177	50	65	0.86	0.0493	0.040	1.2040	0.047	1.4017

Wind Pressure (psf): Panel: (Stress, Deflection, and Web Crippling)

Span (Ft)	Simple Span			2 Equal Spans			3 Equal Spans		
	Stress	Deflection		Stress	Deflection		Stress	Deflection	
		L/60	L/240		L/60	L/240		L/60	L/240
4.0	52	n/c	n/c	56	n/c	n/c	56	n/c	n/c
4.5	41	n/c	37	48	n/c	n/c	50	n/c	n/c
5.0	33	n/c	27	38	n/c	n/c	45	n/c	n/c
5.5	27	n/c	20	32	n/c	n/c	40	n/c	38
6.0	23	n/c	15	27	n/c	n/c	33	n/c	29
6.5	20	n/c	12	23	n/c	n/c	28	n/c	23
7.0	17	n/c	10	20	n/c	n/c	25	n/c	18

Wind Suction (psf): Panel: (Stress and Deflection)

Span (Ft)	Simple Span			2 Equal Spans			3 Equal Spans		
	Stress	Deflection		Stress	Deflection		Stress	Deflection	
		L/60	L/240		L/60	L/240		L/60	L/240
4.0	60	n/c	52	60	n/c	n/c	65	n/c	n/c
4.5	48	n/c	37	48	n/c	n/c	51	n/c	n/c
5.0	38	n/c	27	38	n/c	n/c	41	n/c	n/c
5.5	32	n/c	20	32	n/c	n/c	34	n/c	n/c
6.0	27	n/c	15	27	n/c	n/c	29	n/c	n/c
6.5	23	n/c	12	23	n/c	n/c	24	n/c	23
7.0	20	n/c	10	20	n/c	n/c	21	n/c	18

Wind Suction (psf): Fasteners: (Pull-out, Pull-Over, and Tensile Failure)

Span (Ft)	Purlin Thickness						
	0.060	0.067	0.075	0.089	0.099	0.105	0.120
4.0	59	59	59	59	59	59	59
4.5	52	52	52	52	52	52	52
5.0	47	47	47	47	47	47	47
5.5	43	43	43	43	43	43	43
6.0	39	39	39	39	39	39	39
6.5	36	36	36	36	36	36	36
7.0	34	34	34	34	34	34	34

Contact the engineering team for capacities with different panel configurations.



PRODUCT & ENGINEERING MANUAL

NUCOR REVERSE CLASSIC WALL™ PROPERTY AND SPAN TABLES

Nucor Reverse Classic Wall™ Panel - 26 Gage: Fy = 50 ksi									
Panel Material Information					Panel Properties per foot of panel width				
Panel Gage	Thickness (in.)	Yield (Ksi)	Tensile (Ksi)	Panel Wt. (Psf)	Top in Compression		Bottom in Compression		
					Ix (Gross) (in ⁴)	Sx (eff.) (in ³)	Ma (Kip-in.)	Sx (eff.) (in ³)	Ma (Kip-in.)
26	0.0177	50	65	0.86	0.0493	0.047	1.4017	0.040	1.2040

Wind Pressure (psf): Panel: (Stress, Deflection, and Web Crippling)

Span (Ft)	Simple Span			2 Equal Spans			3 Equal Spans		
	Stress	Deflection		Stress	Deflection		Stress	Deflection	
		L/60	L/240		L/60	L/240		L/60	L/240
4.0	60	n/c	52	56	n/c	n/c	56	n/c	n/c
4.5	48	n/c	37	48	n/c	n/c	50	n/c	n/c
5.0	38	n/c	27	38	n/c	n/c	41	n/c	n/c
5.5	32	n/c	20	32	n/c	n/c	34	n/c	n/c
6.0	27	n/c	15	27	n/c	n/c	29	n/c	n/c
6.5	23	n/c	12	23	n/c	n/c	24	n/c	23
7.0	20	n/c	10	20	n/c	n/c	21	n/c	18

Wind Suction (psf): Panel: (Stress and Deflection)

Span (Ft)	Simple Span			2 Equal Spans			3 Equal Spans		
	Stress	Deflection		Stress	Deflection		Stress	Deflection	
		L/60	L/240		L/60	L/240		L/60	L/240
4.0	52	n/c	n/c	60	n/c	n/c	75	n/c	n/c
4.5	41	n/c	37	48	n/c	n/c	59	n/c	n/c
5.0	33	n/c	27	38	n/c	n/c	48	n/c	n/c
5.5	27	n/c	20	32	n/c	n/c	40	n/c	38
6.0	23	n/c	15	27	n/c	n/c	33	n/c	29
6.5	20	n/c	12	23	n/c	n/c	28	n/c	23
7.0	17	n/c	10	20	n/c	n/c	25	n/c	18

Wind Suction (psf): Fasteners: (Pull-out, Pull-Over, and Tensile Failure)

Span (Ft)	Purlin Thickness						
	0.060	0.067	0.075	0.089	0.099	0.105	0.120
4.0	59	59	59	59	59	59	59
4.5	52	52	52	52	52	52	52
5.0	47	47	47	47	47	47	47
5.5	43	43	43	43	43	43	43
6.0	39	39	39	39	39	39	39
6.5	36	36	36	36	36	36	36
7.0	34	34	34	34	34	34	34

n/c = value does not control (i.e. value is greater than controlling stress value)

Contact the engineering team for capacities with different panel configurations.

LAST REVISION
 DATE: 03/11/15
 BY: AAJ CHK: MDK



PRODUCT & ENGINEERING MANUAL

NUCOR ACCENT WALL™ PROPERTY AND SPAN TABLES

Nucor Accent Wall™ Panel - 26 Gage: Fy = 50 ksi									
Panel Material Information					Panel Properties per foot of panel width				
Panel Gage	Thickness (in.)	Yield (Ksi)	Tensile (Ksi)	Panel Wt. (Psf)	Top in Compression		Bottom in Compression		
					Ix (Gross) (in ⁴)	Sx (eff.) (in ³)	Ma (Kip-in.)	Sx (eff.) (in ³)	Ma (Kip-in.)
26	0.0177	50	65	0.86	0.0320	0.042	1.2633	0.036	1.0900

Wind Pressure (psf): Panel: (Stress, Deflection, and Web Crippling)

Span (Ft)	Simple Span			2 Equal Spans			3 Equal Spans		
	Stress	Deflection		Stress	Deflection		Stress	Deflection	
		L/60	L/240		L/60	L/240		L/60	L/240
4.0	54	n/c	34	54	n/c	n/c	56	n/c	n/c
4.5	43	n/c	24	43	n/c	n/c	46	n/c	45
5.0	35	n/c	17	35	n/c	n/c	37	n/c	33
5.5	29	n/c	13	29	n/c	n/c	31	n/c	25
6.0	24	n/c	10	24	n/c	24	26	n/c	19
6.5	21	n/c	8	21	n/c	19	22	n/c	15
7.0	18	n/c	6	18	n/c	15	19	n/c	12

Wind Suction (psf): Panel: (Stress and Deflection)

Span (Ft)	Simple Span			2 Equal Spans			3 Equal Spans		
	Stress	Deflection		Stress	Deflection		Stress	Deflection	
		L/60	L/240		L/60	L/240		L/60	L/240
4.0	47	n/c	34	54	n/c	n/c	68	n/c	64
4.5	37	n/c	24	43	n/c	n/c	54	n/c	45
5.0	30	n/c	17	35	n/c	n/c	43	n/c	33
5.5	25	n/c	13	29	n/c	n/c	36	n/c	25
6.0	21	n/c	10	24	n/c	24	30	n/c	19
6.5	18	n/c	8	21	n/c	19	26	n/c	15
7.0	15	n/c	6	18	n/c	15	22	n/c	12

Wind Suction (psf): Fasteners: (Pull-out, Pull-Over, and Tensile Failure)

Span (Ft)	Purlin Thickness						
	0.060	0.067	0.075	0.089	0.099	0.105	0.120
4.0	59	59	59	59	59	59	59
4.5	52	52	52	52	52	52	52
5.0	47	47	47	47	47	47	47
5.5	43	43	43	43	43	43	43
6.0	39	39	39	39	39	39	39
6.5	36	36	36	36	36	36	36
7.0	34	34	34	34	34	34	34

n/c = value does not control (i.e. value is greater than controlling stress value)

Contact the engineering team for capacities with different panel configurations.

LAST REVISION
 DATE: 03/11/15
 BY: AAJ CHK: MDK