



## **SECONDARY FRAMING TABLE OF CONTENTS**

Secondary Framing Table of Contents.....	1
Secondary Framing.....	2
“Z” Section Properties.....	3
“C” Section Properties.....	4
“S” Section Properties.....	5
“Z” Roof Purlins.....	6
“Z” Wall Girts.....	7
“Z” Wall Girts (Inset/Flush).....	7
“Z” Wall Girts (Bypass Bolted Clips).....	8
“Z” Wall Girts (Bypass Welded Clips).....	9
Open Web Roof/Mezzanine Joists.....	10
ClearBay® Bridging:.....	10
Open-Web Welded Joists.....	11
Open-Web All Bolted Joists.....	12
Open Web Bolted Joist Detail (Continued).....	13
Cold-Formed Box Beams.....	14
Standard Purlin Spacing.....	15
Standard Purlin Spacing (Gable Building).....	15
Standard Purlin Spacing (Single Slope Building).....	16
Standard Girt Spacing.....	17



## SECONDARY FRAMING

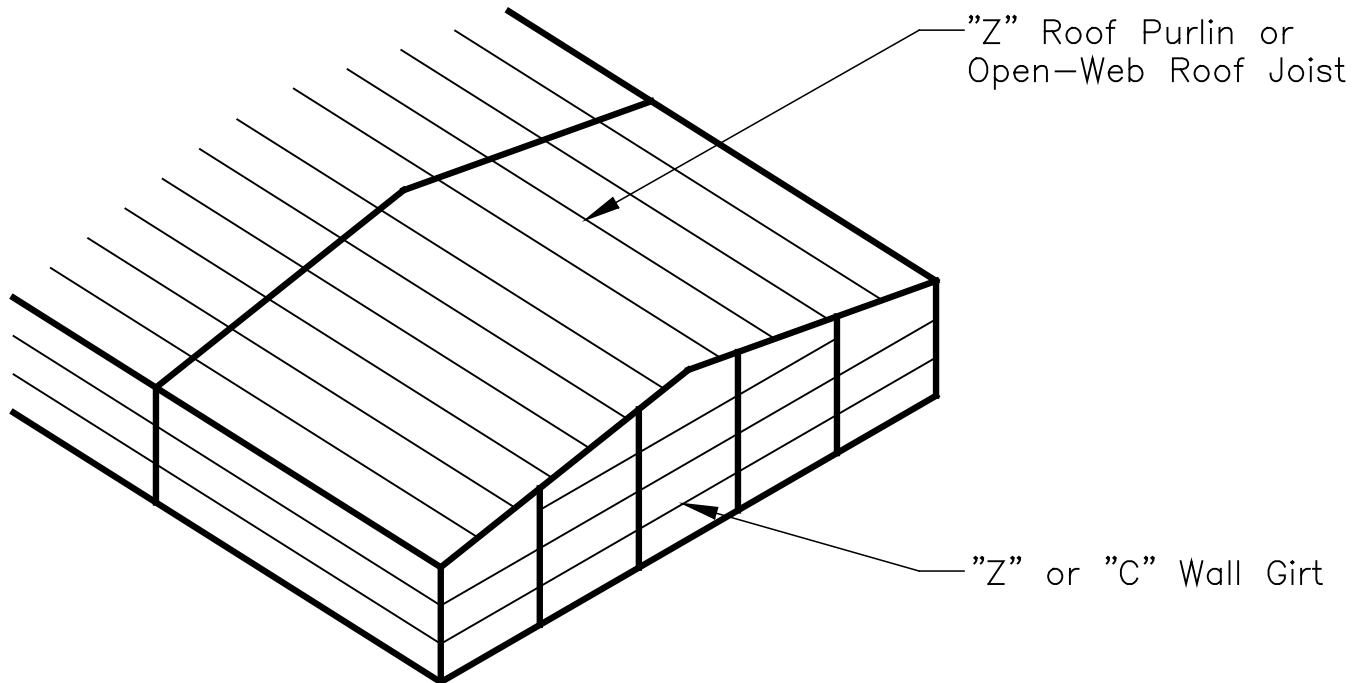

1. Standard Secondary Framing consists of Cold Formed "Z" shaped roof purlins and wall girts. "C" shaped wall girts may be used for framed openings and other special applications.
2. "Z" and "C" members are shop punched for simple field bolted connections.
3. "Z" and "C" members are available in 8, 10, or 12 inch depths. Consult the engineering team for specifics.
4. Optional Open-Web joists are available for wide bay applications with spans over 35 feet, and for mezzanine applications.
5. Section properties listed in this section are determined using the AISI North American Specification for the Design of Cold-Formed Steel Structural Members (AISI S100), Latest Edition. Capacities listed represent "fully braced" capacities and are shown without reduction. Any use of these properties for design should also be completed utilizing the required AISI S100 provisions.
6. As a standard, all bypass roof purlins and wall girts will utilize a shop welded clip. Bolted clips are also available.

**Some Nucor Divisions may offer welded clips for inset or flush girts. Contact your NBS Division for availability.**



# PRODUCT & ENGINEERING MANUAL

## “Z” SECTION PROPERTIES

Section Designation	D (in.)	B (in.)	Nominal t (in.)	Design Wt. (plf)	Gross Ix (in <sup>4</sup> )	Effective Sx (in <sup>3</sup> )	Ma (in-kip)	
							ASD	LSD
08 Z 054	8.00	2.50	0.054	2.65	7.522	1.605	52.850	79.434
08 Z 060	8.00	2.50	0.060	2.94	8.343	1.898	62.518	93.965
08 Z 067	8.00	2.50	0.067	3.29	9.297	2.134	70.268	105.610
08 Z 075	8.00	2.50	0.075	3.68	10.383	2.464	81.158	121.980
08 Z 089	8.00	2.50	0.089	4.36	12.269	3.067	101.020	151.830
08 Z 099	8.00	2.50	0.099	4.85	13.606	3.402	112.030	168.370
08 Z 105	8.00	2.50	0.105	5.15	14.404	3.601	118.600	178.250
<hr/>								
10 Z 060	10.00	2.50	0.060	3.35	14.155	2.353	77.500	116.480
10 Z 067	10.00	2.50	0.067	3.74	15.782	2.774	91.351	137.300
10 Z 075	10.00	2.50	0.075	4.19	17.635	3.355	110.480	166.060
10 Z 089	10.00	2.50	0.089	4.97	20.860	4.172	137.400	206.520
10 Z 099	10.00	2.50	0.099	5.53	23.152	4.630	152.500	229.200
10 Z 105	10.00	2.50	0.105	5.86	24.522	4.904	161.520	242.760
10 Z 120	10.00	2.50	0.120	6.70	27.930	5.586	183.970	276.500
<hr/>								
12 Z 075	12.00	3.50	0.075	5.21	32.685	4.048	133.330	200.390
12 Z 089	12.00	3.50	0.089	6.18	38.691	5.350	176.200	264.830
12 Z 099	12.00	3.50	0.099	6.87	42.963	6.246	205.700	309.160
12 Z 105	12.00	3.50	0.105	7.29	45.519	6.704	220.800	331.870
12 Z 120	12.00	3.50	0.120	8.33	51.883	8.049	265.070	398.400

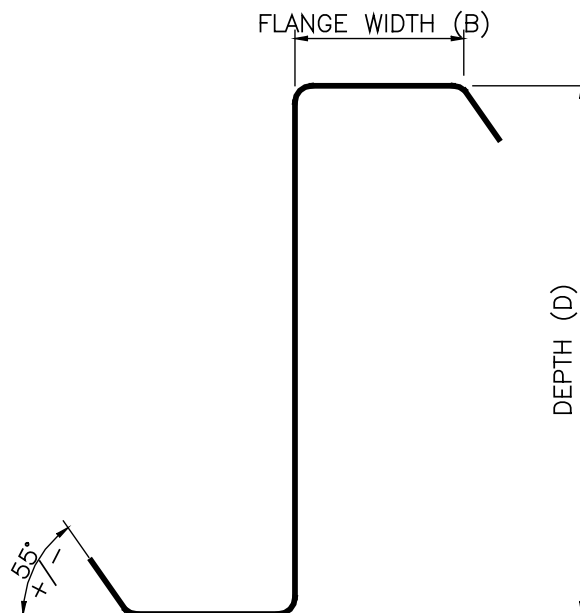

LAST REVISION  
 DATE: 03/10/15  
 BY: AAJ CHK: MDK

DETAIL NAME IF APPLICABLE  
**SF0020PE.DWG**

**4.3.3**



# PRODUCT & ENGINEERING MANUAL

## “C” SECTION PROPERTIES

Section Designation	D (in.)	B (in.)	Nominal t (in.)	Design Wt. (plf)	Gross Ix (in <sup>4</sup> )	Effective Sx (in <sup>3</sup> )	Ma (in-kip)	
							ASD	LSD
08 C 060	8.00	2.75	0.060	2.94	8.393	1.759	57.928	87.066
08 C 067	8.00	2.75	0.067	3.29	9.351	2.033	66.944	100.620
08 C 075	8.00	2.75	0.075	3.68	10.440	2.313	76.182	114.500
08 C 089	8.00	2.75	0.089	4.36	12.330	2.924	96.287	144.720
08 C 099	8.00	2.75	0.099	4.85	13.669	3.318	109.270	164.240
08 C 105	8.00	2.75	0.105	5.15	14.467	3.557	117.150	176.080
<hr/>								
10 C 060	10.00	2.75	0.060	3.35	14.218	2.176	71.655	107.700
10 C 067	10.00	2.75	0.067	3.74	15.850	2.599	85.585	128.630
10 C 075	10.00	2.75	0.075	4.19	17.707	3.139	103.390	155.390
10 C 089	10.00	2.75	0.089	4.97	20.938	3.980	131.060	196.980
10 C 099	10.00	2.75	0.099	5.53	23.231	4.514	148.660	223.440
10 C 105	10.00	2.75	0.105	5.86	24.601	4.839	159.360	239.520

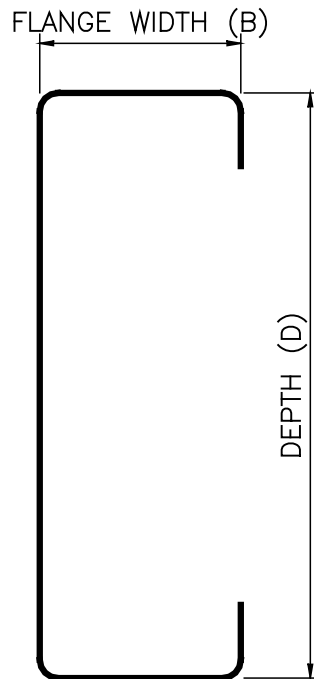

LAST REVISION  
 DATE: 03/10/15  
 BY: AAJ CHK: MDK

DETAIL NAME IF APPLICABLE  
**SF0030PE.DWG**

**4.3.4**



# PRODUCT & ENGINEERING MANUAL

## “S” SECTION PROPERTIES

Section Designation	D (in.)	B (in.)	Nominal t (in.)	Design Wt. (plf)	Gross Ix (in <sup>4</sup> )	Effective Sx (in <sup>3</sup> )	Ma (in-kip)	
							ASD	LSD
08 S 075	8.00	3.625	0.075	4.19	12.684	2.592	85.362	128.300
08 S 089	8.00	3.625	0.089	4.97	14.980	3.169	104.380	156.880
08 S 099	8.00	3.625	0.099	5.53	16.605	3.593	118.340	177.870
08 S 105	8.00	3.625	0.105	5.87	17.575	3.872	127.520	191.660
08 S 120	8.00	3.625	0.120	6.71	19.981	4.673	153.890	231.300
12 S 075	12.00	3.625	0.075	5.21	32.598	4.051	133.430	200.540
12 S 089	12.00	3.625	0.089	6.18	38.573	5.379	177.140	266.240
12 S 099	12.00	3.625	0.099	6.87	42.818	6.278	206.760	310.760
12 S 105	12.00	3.625	0.105	7.29	45.357	6.747	222.210	333.980
12 S 120	12.00	3.625	0.120	8.33	51.673	8.083	266.200	400.100

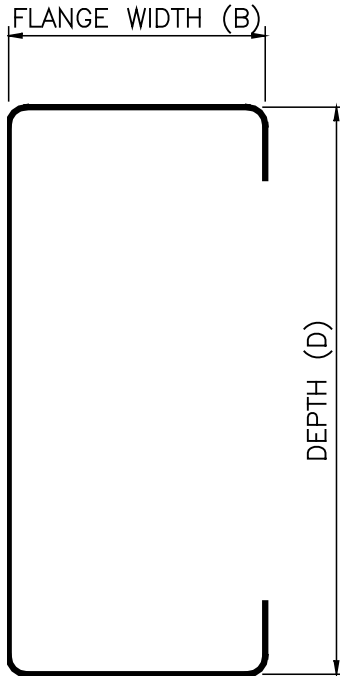

LAST REVISION  
 DATE: 03/10/15  
 BY: AAJ CHK: MDK

DETAIL NAME IF APPLICABLE  
**SF0040PE.DWG**



## “Z” ROOF PURLINS

**TYPICAL WASHER REQUIREMENTS**  
**ERECTOR NOTE**  
(UNLESS NOTED OTHERWISE ON DRAWINGS)

	<p><b>SLOT TO SLOT CONNECTIONS</b> WASHERS ARE REQUIRED ON BOTH SIDES OF MATERIAL IF SLOTS ARE USED ON BOTH SIDES. (SEE DETAIL AT RIGHT FOR LAPPED ZEE MEMBERS)</p>
	<p><b>SLOT TO HOLE CONNECTIONS</b> ONE WASHER REQUIRED ON SLOTTED SIDE ONLY.</p>
	<p><b>HOLE TO HOLE CONNECTIONS</b> NO WASHERS ARE REQUIRED WHEN SLOTS ARE NOT USED.</p>

**WASHER PART NUMBERS**

H0200 - 1/2" FLAT WASHER	H0240 - 1" FLAT WASHER
H0210 - 5/8" FLAT WASHER	H0250 - 1 1/8" FLAT WASHER
H0220 - 3/4" FLAT WASHER	H0260 - 1 1/4" FLAT WASHER
H0230 - 7/8" FLAT WASHER	

**SECTION "A"**

**SECTION "B"**

**LAPPED/NESTED REGION**

NO WASHERS REQUIRED AT BOLTS USED IN THE LAPPED REGIONS OF ZEE MEMBERS.

### NOTES:

- 1) ALL PURLIN CONNECTIONS UTILIZE 1/2" DIAMETER BOLTS.
- 2) “Z” PURLINS HAVE SYMMETRICAL FLANGES FOR EASE OF ERECTION.
- 3) “Z” PURLINS ARE ECONOMICAL FOR SPANS UP TO AND INCLUDING 40 FEET.



## “Z” WALL GIRTS

### “Z” WALL GIRTS (INSET/FLUSH)

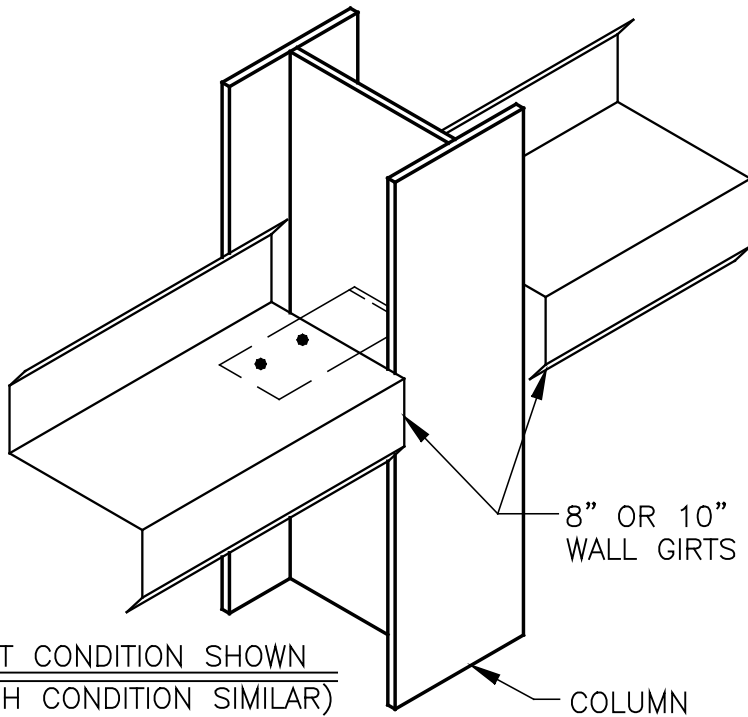

INSET CONDITION SHOWN  
(FLUSH CONDITION SIMILAR)

COLUMN

#### NOTES

- 1) ALL WALL GIRT CONNECTIONS UTILIZE 1/2" DIA. BOLTS.
- 2) INSET CONDITION IS STANDARD ON ENDWALLS. INSET CONDITION IS OPTIONAL ON SIDEWALLS.
- 3) "Z" GIRTS ARE ECONOMICAL FOR SPANS UP TO AND INCLUDING 40 FEET.
- 4) 8 AND 10 INCH "C" SHAPED MEMBERS ARE AVAILABLE AS WALL GIRTS AS AN OPTION.
- 5) FLUSH GIRTS ARE NOT RECOMMENDED FOR PROJECTS WITH CLASSIC WALL BECAUSE THE COLUMN LOCATIONS MAY BE VISIBLE FROM THE EXTERIOR OF THE BUILDING DUE TO THE INSULATION BEING COMPRESSED TO 0".

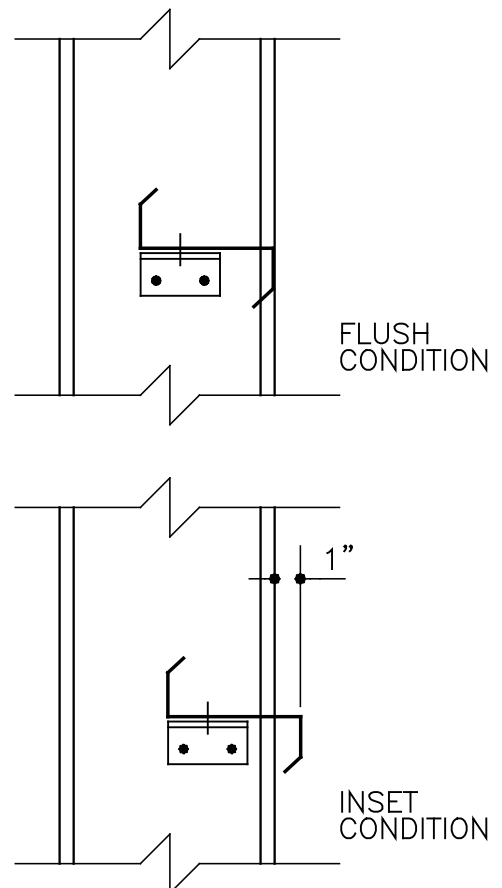



# PRODUCT & ENGINEERING MANUAL

## "Z" WALL GIRTS (BYPASS BOLTED CLIPS)

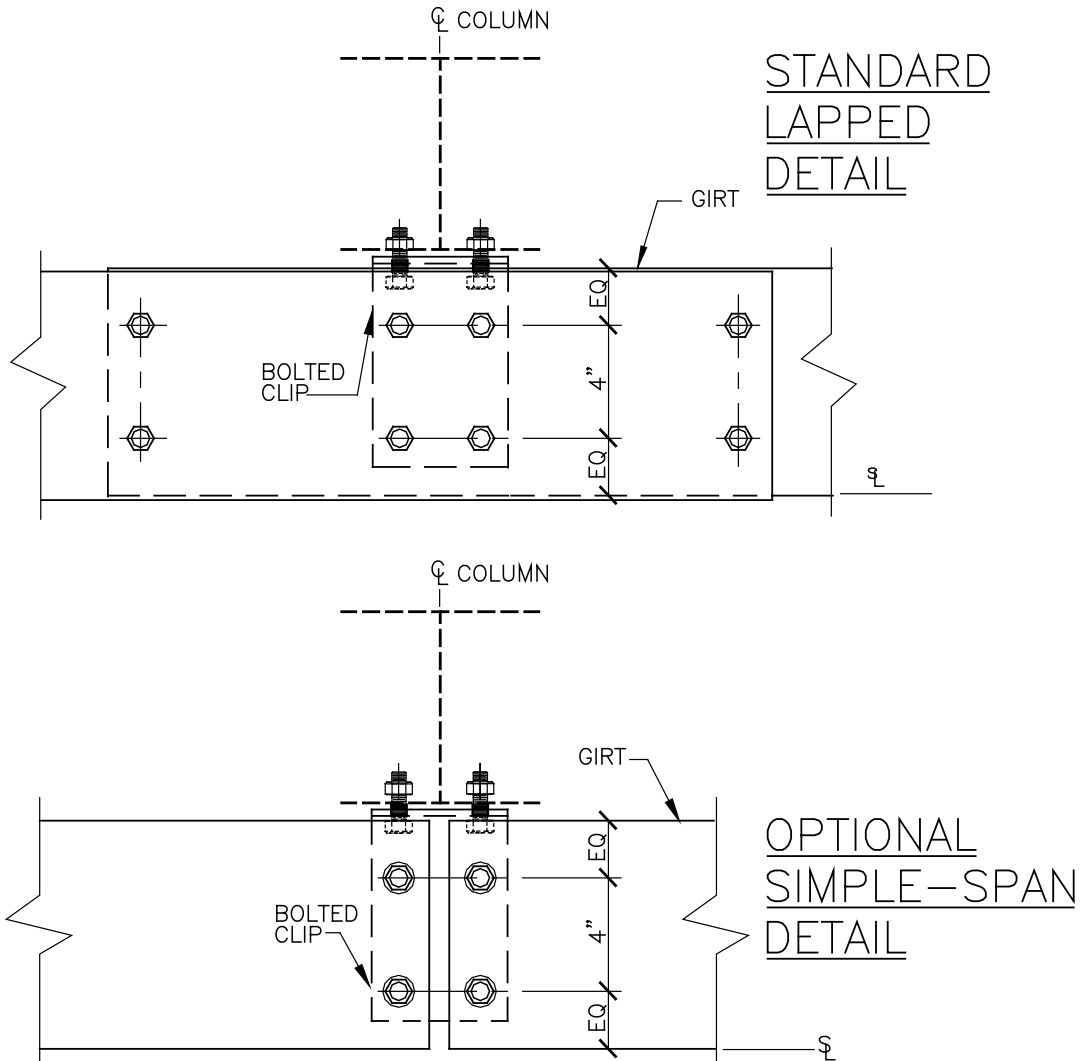

### NOTES

- 1) ALL WALL GIRTS CONNECTIONS UTILIZE 1/2" DIAMETER BOLTS.
- 2) BYPASS CONDITION IS STANDARD ON SIDEWALLS, OPTIONAL ON ENDWALLS.
- 3) "Z" GIRTS ARE ECONOMICAL FOR SPANS UP TO 40 FEET.
- 4) 8 AND 10 INCH "C" SHAPED MEMBERS ARE AVAILABLE FOR WALL GIRTS AS AN OPTION.

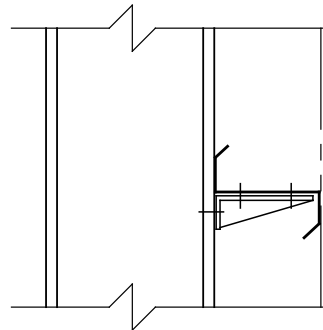

LAST REVISION  
DATE: 08/06/04  
BY: KMC CHK: RJF

DETAIL NAME IF APPLICABLE  
**SF0060PE.DWG**

**4.3.8**





# PRODUCT & ENGINEERING MANUAL

## "Z" WALL GIRTS (BYPASS WELDED CLIPS)

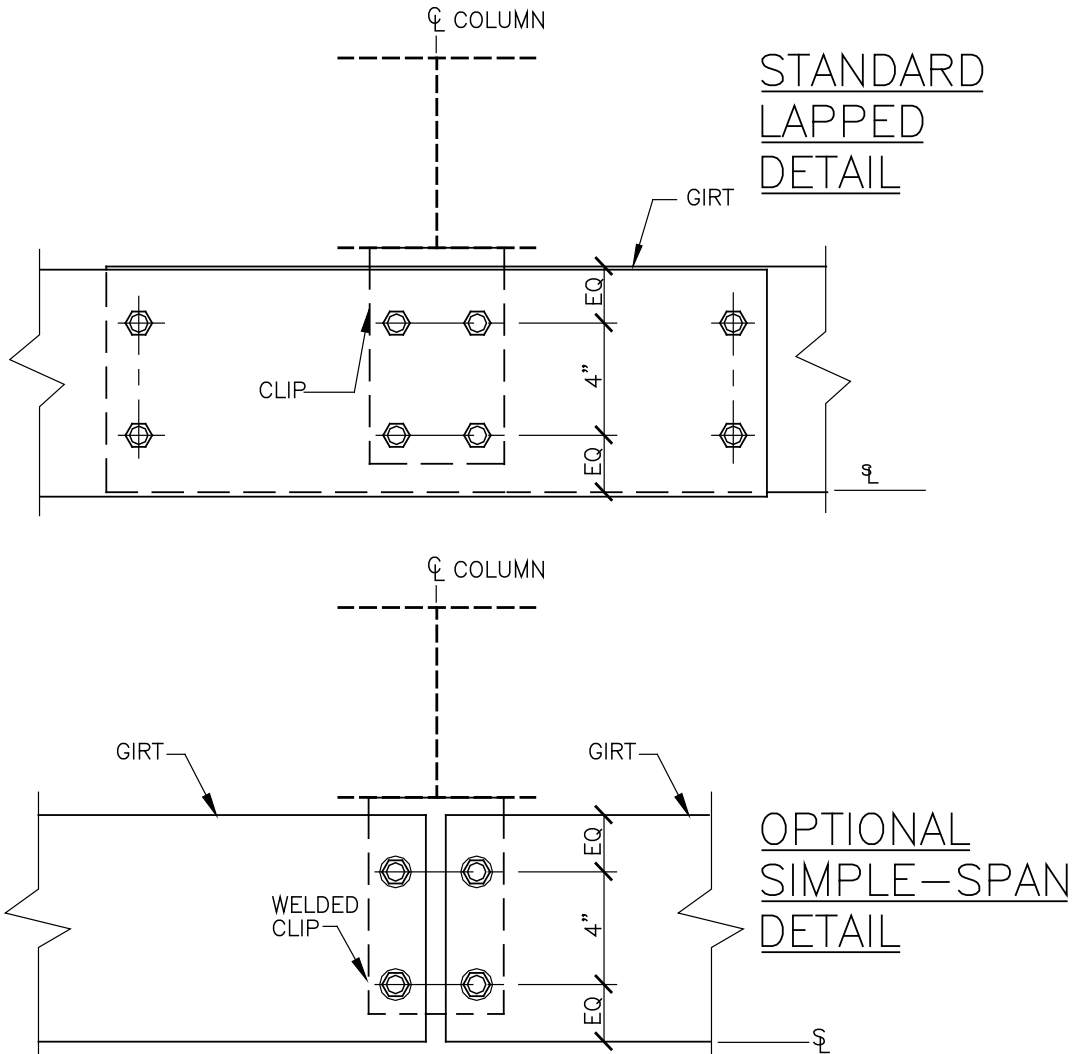

### NOTES

- 1) ALL WALL GIRTS CONNECTIONS UTILIZE 1/2" DIAMETER BOLTS.
- 2) BYPASS CONDITION IS STANDARD ON SIDEWALLS, OPTIONAL ON ENDWALLS.
- 3) "Z" GIRTS ARE ECONOMICAL FOR SPANS UP TO 40 FEET.
- 4) 8 AND 10 INCH "C" SHAPED MEMBERS ARE AVAILABLE FOR WALL GIRTS AS AN OPTION.

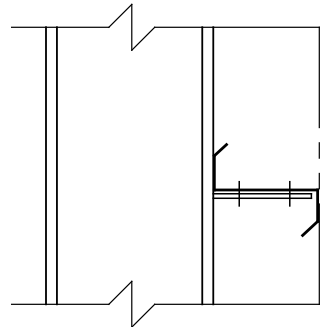

LAST REVISION  
 DATE: 08/06/04  
 BY: KMC CHK: RJF

DETAIL NAME IF APPLICABLE  
**SF0065PE.DWG**

**4.3.9**



## OPEN WEB ROOF/MEZZANINE JOISTS

### CLEARBAY® BRIDGING:

Providing spacious bays of up to 60', ClearBay® is the roof joist system incorporating the Nucor CFR™, VR16 II™ Vertical Rib, and Insulated Roof Panel systems and provides the ultimate in versatility and open spaces for any number of applications, including hangars, large indoor recreational buildings, and even storage facilities. By partnering with our sister division, Vulcraft, NBS is able to engineer the most economical roof joist system for your metal building.

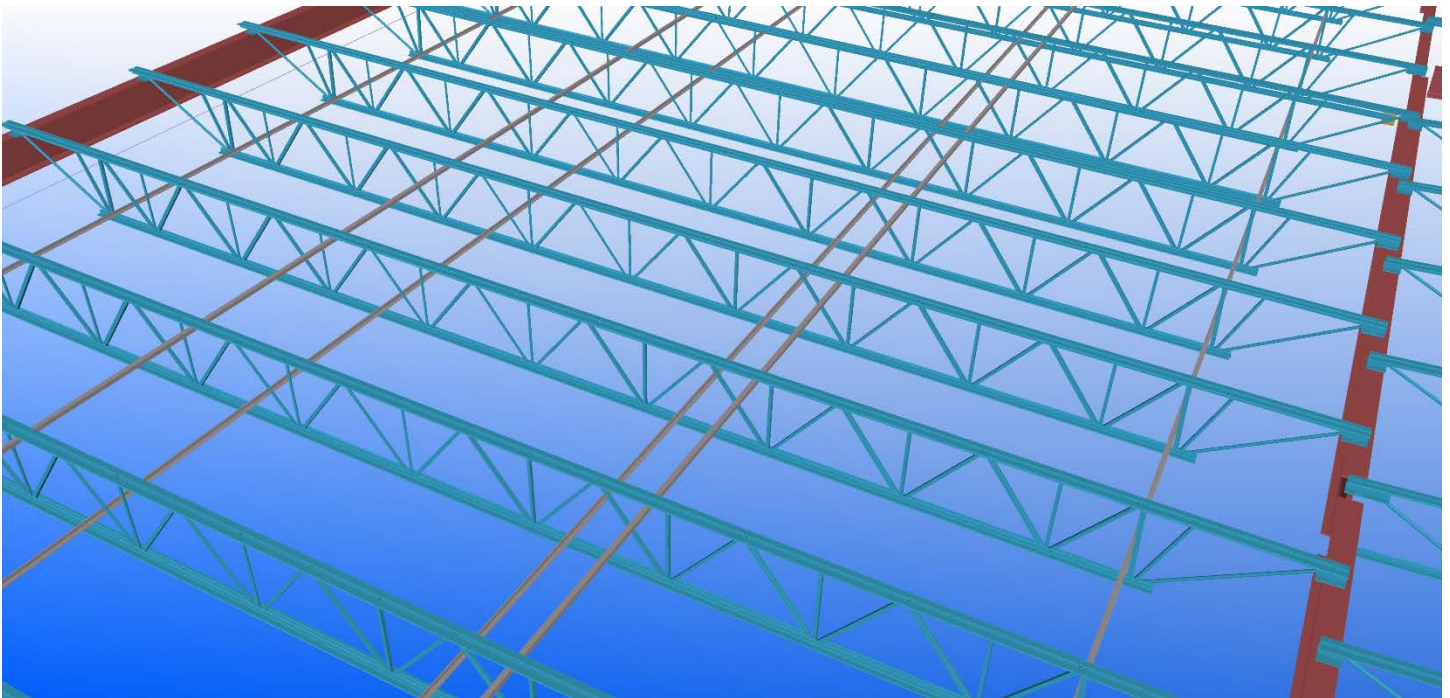



# PRODUCT & ENGINEERING MANUAL

## OPEN-WEB WELDED JOISTS

LAST REVISION  
DATE: 06/11/09  
BY: AES CHK: \_\_\_\_\_

DETAIL NAME IF APPLICABLE  
**SF0070PE.DWG**

**4.3.11**



# PRODUCT & ENGINEERING MANUAL

## OPEN-WEB ALL BOLTED JOISTS

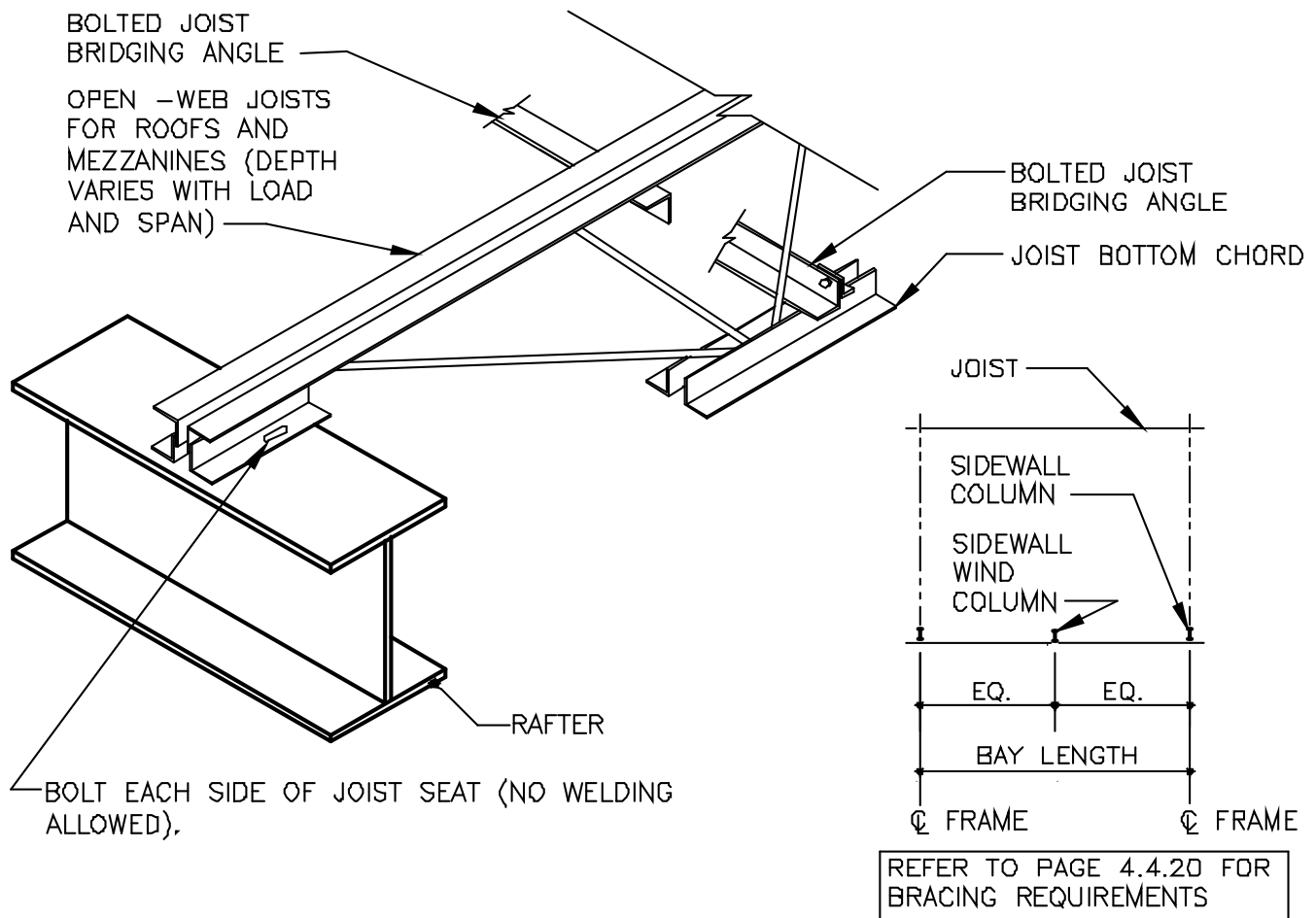

### NOTES

- 1) OPEN-WEB JOISTS ARE ECONOMICAL FOR SPANS OVER 40 FEET.
- 2) SIDEWALL WIND COLUMNS ARE CENTERED IN THE BAYS UNLESS NOTED OTHERWISE ON THE ORDER DOCUMENTS, PLEASE SPECIFY REQUIREMENTS ON THE ORDER DOCUMENTS.
- 3) EAVE AND RAKE EXTENSIONS ARE NOT AVAILABLE ON JOIST BUILDINGS.
- 4) BOLTED BRIDGING IS REQUIRED AT THE TOP AND BOTTOM CHORDS OF THE JOISTS. NUMBER OF ROWS VARIES BASED UPON LOADS AND BAY SIZES.
- 5) ALL CONNECTIONS WILL BE BOLTED OR DRILL-BOLTED.

LAST REVISION  
DATE: 03/10/15  
BY: AAJ CHK: MDK

DETAIL NAME IF APPLICABLE  
**SF0071PE.DWG**

**4.3.12**



# PRODUCT & ENGINEERING MANUAL

## OPEN WEB BOLTED JOIST DETAIL (CONTINUED)

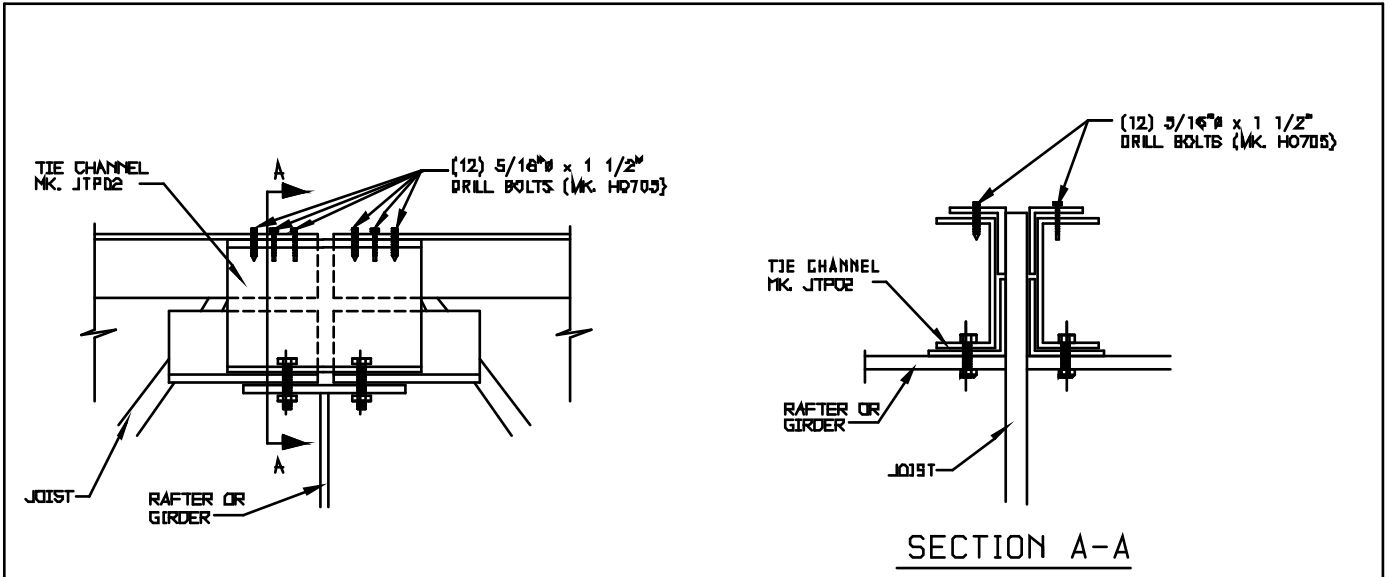

ALL BOLTED STRUT JOIST ATTACHMENT

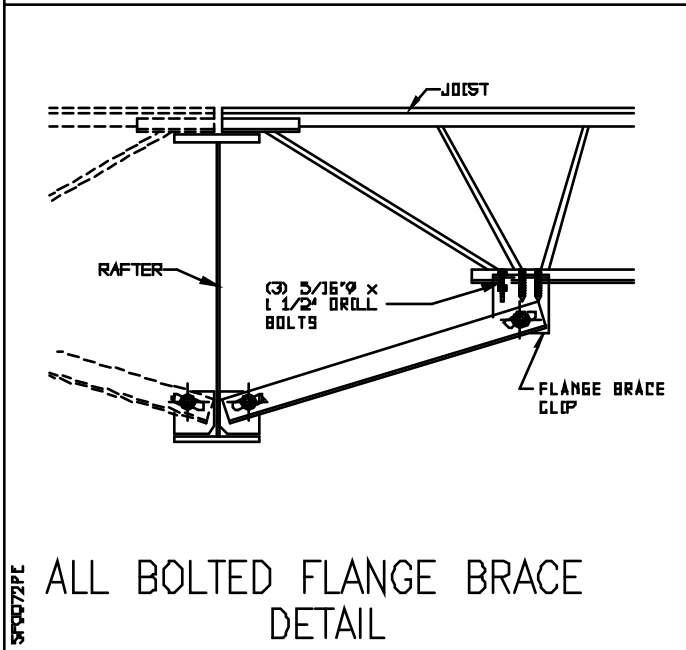

ALL BOLTED FLANGE BRACE  
DETAIL

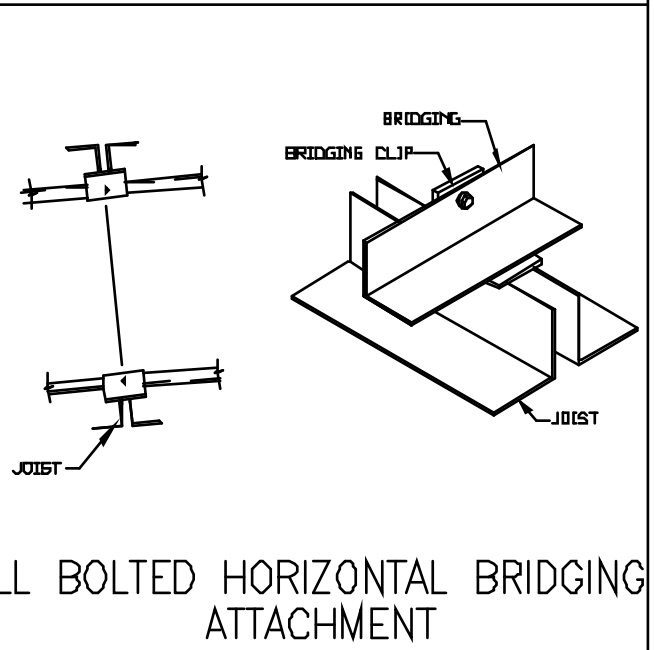

ALL BOLTED HORIZONTAL BRIDGING  
ATTACHMENT



## COLD-FORMED BOX BEAMS

1. Cold-formed box beams consist of two “C” or “S” sections, forming a cold-formed “box”.
2. These sections may be square or rectangular in shape.
3. The height of the box beam matches the purlin depth. The depth of the box beam will be 8”, 10”, or 12”, depending on the design requirements of a particular project.
4. Cold-formed box beams are typically used as a replacement for the eave strut, eave purlin, or strong-back eave beam.
5. Standard connection for the box beam to primary framing member is with either (2) or (4) ½” diameter A325 bolts per end.

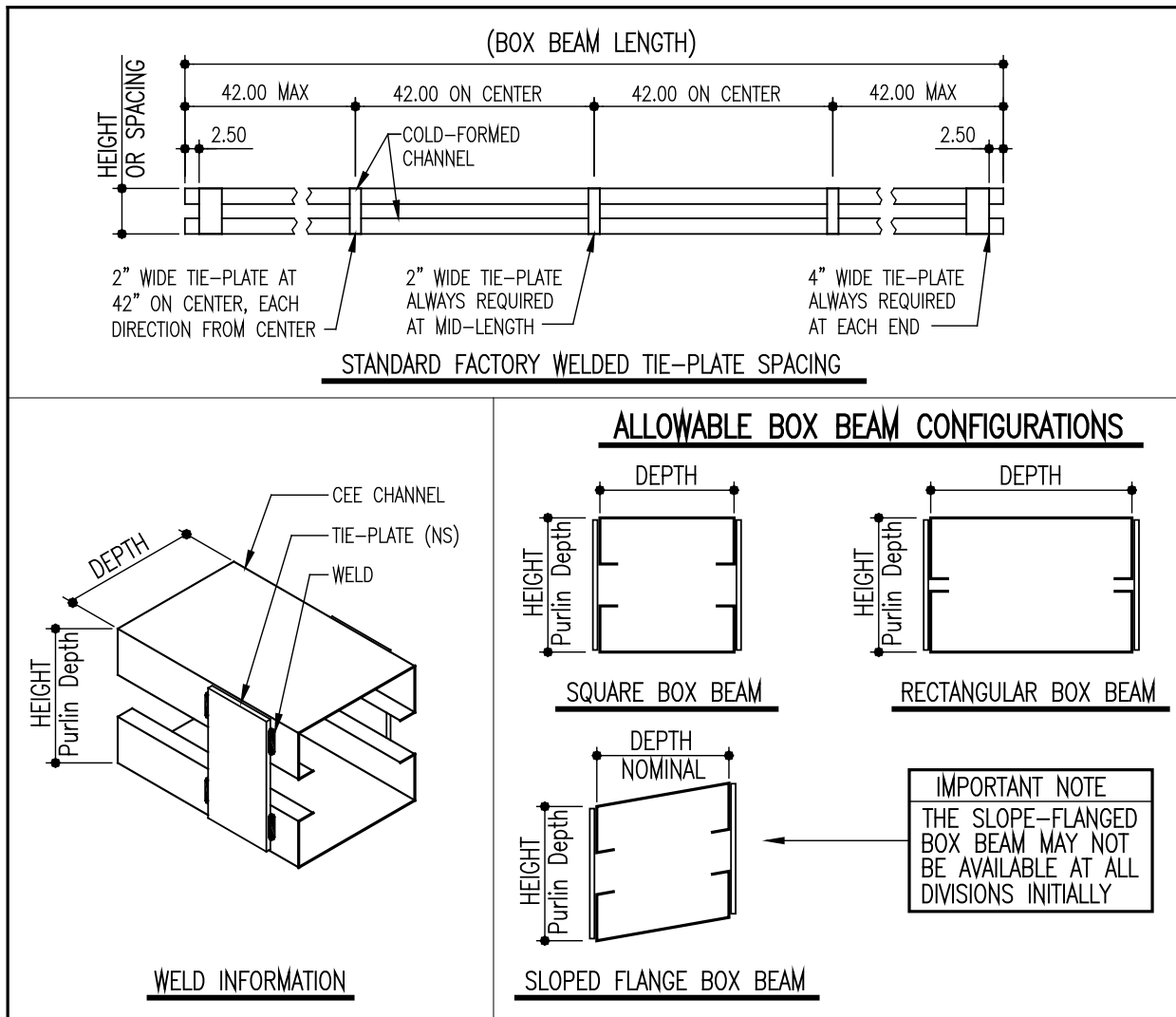



## STANDARD PURLIN SPACING

### STANDARD PURLIN SPACING (GABLE BUILDING)

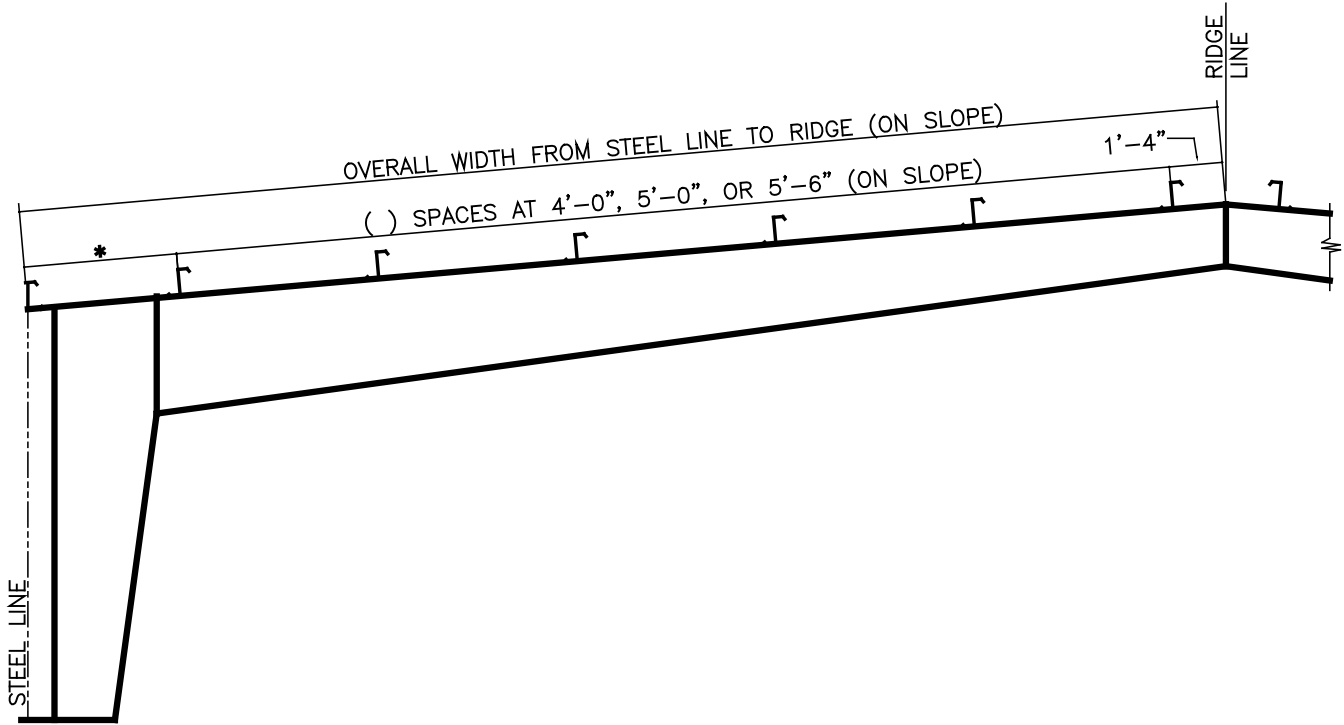

\* INDICATES ODD SPACE AS FOLLOWS:

ROOF SLOPE	PURLIN SPACE	
< 1/2:12	MIN. = 1'-10"	MAX = 3'-10"
≥ 1/2:12	MIN. = 1'-10"	MAX = 5'-6"

NOTE: THESE SPACINGS ARE TO BE USED FOR BOTH NUCOR "CFR"<sup>TM</sup> AND NUCOR "CLASSIC ROOF"<sup>TM</sup> SYSTEMS.

WITH NUCOR "CFR"<sup>TM</sup> ROOF (UL CLASS 90, UL 580, CONSTRUCTION NO. 590).

- MAXIMUM PURLIN SPACING IS 5'-0" W/ PURLINS.
- MAXIMUM PURLIN SPACING IS 5'-6" W/ JOISTS.



# PRODUCT & ENGINEERING MANUAL

## STANDARD PURLIN SPACING (SINGLE SLOPE BUILDING)

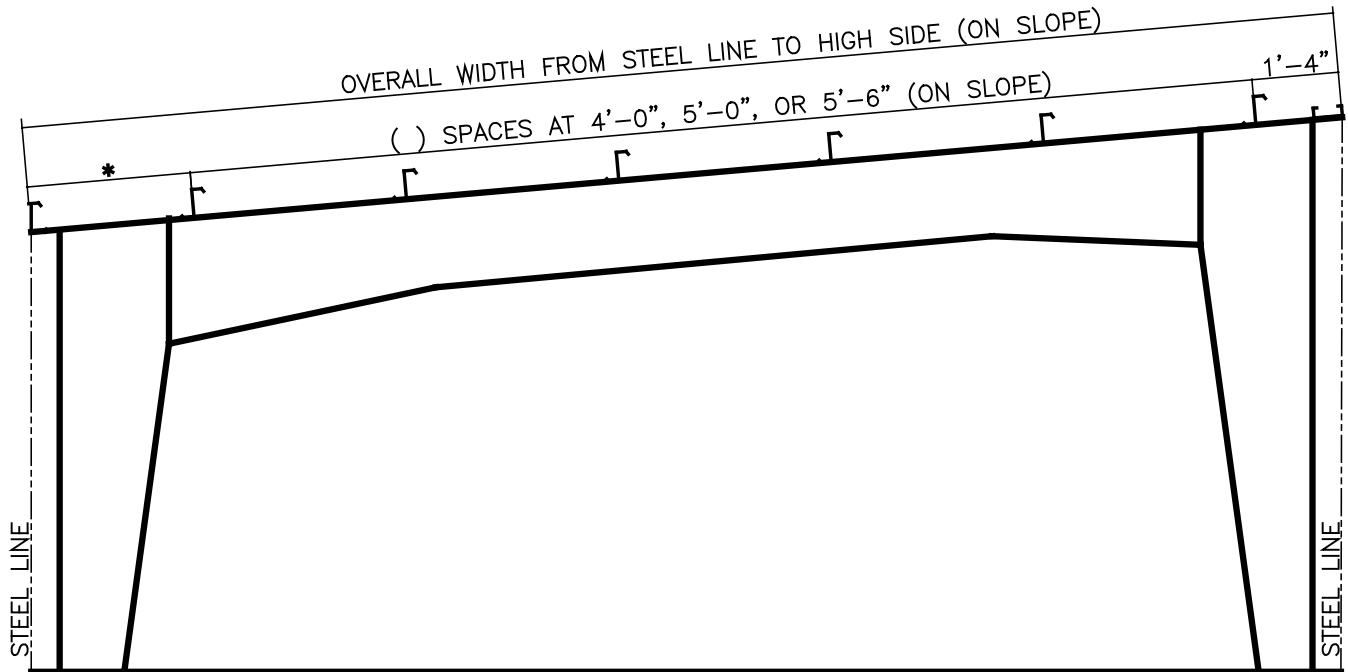

* INDICATES ODD SPACE AS FOLLOWS:	
ROOF SLOPE	PURLIN SPACE
< 1/2:12	MIN. = 1'-10"      MAX = 3'-10"
≥ 1/2:12	MIN. = 1'-10"      MAX = 5'-6"

NOTE: THESE SPACINGS ARE TO BE USED FOR BOTH NUCOR "CFR"<sup>TM</sup> AND NUCOR "CLASSIC ROOF"<sup>TM</sup> SYSTEMS.

WITH NUCOR "CFR"<sup>TM</sup> ROOF (UL CLASS 90, UL 580, CONSTRUCTION NO. 590).

- MAXIMUM PURLIN SPACING IS 5'-0" W/ PURLINS.
- MAXIMUM PURLIN SPACING IS 5'-6" W/ JOISTS.





## STANDARD GIRT SPACING

