

NUCOR

BUILDING SYSTEMS

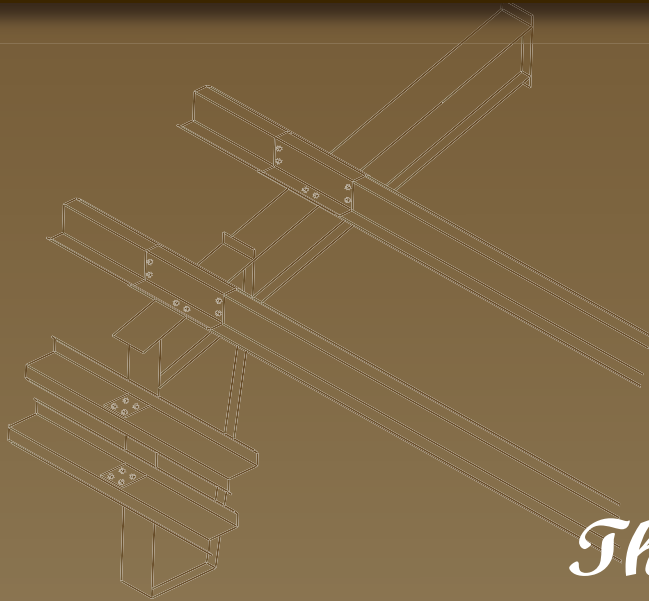

The Brand of Choice

NUCOR VR16 II™ ROOF SYSTEMS

www.nucorbuildingsystems.com



NUCOR VR16 II™ VERTICAL RIB STANDING SEAM



Nucor Building Systems is a Nucor company. Nucor Corporation is a Fortune 500 Company, producing steel and steel products. Nucor has been heavily involved in industrial and commercial projects for many years. Nucor has earned a reputation for providing the highest quality products and an outstanding record for customer satisfaction.

Complete metal building packages can be customized and combined with other materials such as storefront glass and masonry to produce a cost effective, aesthetically sound building designed for your special requirements.

As a custom manufacturer, Nucor produces a wide array of structural systems including clearspan rigid frame, modular rigid frame, tapered beam, and lean-to. All are available in standard or long span options. Crane support systems and mezzanines can also be included as part of the complete building package. Your Nucor building can be designed to virtually any desired dimension to achieve the optimal solution for your building requirements.

Nucor Building Systems is one of the most flexible and diverse building manufacturers in operation today.

PERFECT FOR THE MARKETPLACE

The Nucor Building Systems VR16 II Roof Panel is a Structural Standing Seam Vertical Rib Panel that is perfect for architectural requirements in today's marketplace. The Nucor VR16 II Roof System panel is a weathertight system that is an ideal solution for buildings with hips and valleys. The VR16 II roof panel offers an attractive architectural roof system available both in Galvalume® and Kynar 500® finishes as standard. The panels are installed with concealed fastener clips allowing for thermal movement. It is mechanically seamed for weather tightness.



IAS ACCREDITATION



Nucor Building Systems is IAS AC472 accredited. IAS (International Accreditation Service) in cooperation with the MBMA, is the new, high quality standard certification program written specifically for the metal building industry. AC472 consists of three parts: structural, cold formed, and design, and encompasses all manufacturing practices and engineering common to the pre-engineered metal building manufacturing industry.



THE IDEAL ROOF PANEL SOLUTION

Performance and Testing

ASTM E108 Test Methods for Fire Tests of Roof Coverings

ASTM E283 Test Method for Determining Air Leakage through Wall Systems

ASTM E331 Test Method for Water Penetration of Exterior Wall Systems

ASTM E1592 Test Method for Wind Uplift Performance of Sheet Metal Roofing Systems

ASTM E1646 Test Method for Water Penetration of Exterior Roof Systems

ASTM E1680 Test Method for Rate of Air Leakage Through Exterior Roof Systems



AISI Gravity & Uplift Base Testing

AISI Purlin Stability Testing

US Army Corps of Engineers – Approved per

CEGS 07416 test specification

FM Simulated Hail Damage Testing – Class SH Hail Resistance



Factory Mutual/UL90	Gauge	Secondary	Spacing	Seam Option
Factory Mutual 1-60	24	Purlins or Joists	5'-0"	Nucor Vise Lock 360™
Factory Mutual 1-90	24	Purlins or Joists	3'-4"	Nucor Vise Lock 360
Factory Mutual 1-120	24	Purlins or Joists	2'-6"	Nucor Vise Lock 360
Up to Factory Mutual 1-180	22	Purlins or Joists	Varies	Nucor Vise Lock 360
UL90®	24	Purlins or Joists	5'-0"	Nucor Vise Lock™ Nucor Vise Lock 360

Seaming Options Available

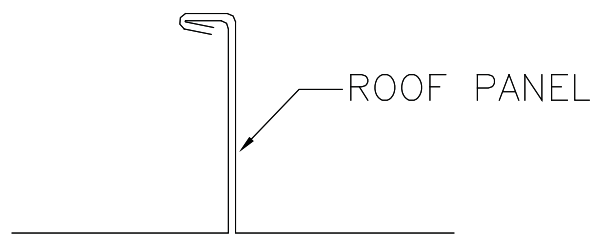

Nucor Vise Lock Seam

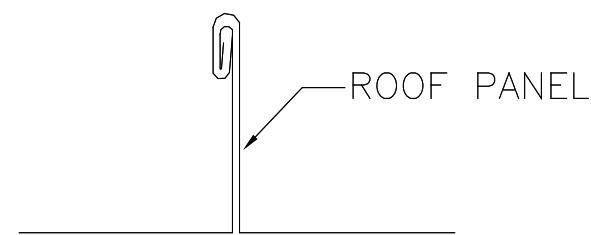

Nucor Vise Lock 360 Seam

PRODUCT SPECIFICATIONS

Panel Details

- Rib height: 2"
- Cover width: 16"
- Galvalume finish
- Factory sealant continuously applied along female rib
- Minor striations to help reduce "oil canning"
- Painted Kynar finishes
- Standard 24 gauge material (22 gauge also available)
- Mechanically seamed for weathertight installation
- Panel installed with concealed fastener clips that allow for thermal movement
- 1/2:12 Minimum roof slope required



Nucor VR16 II Warranties



25 Year Galvalume Finish

25 & 30 Year Kynar 500 (Fluoroceram®) Paint Finish

20 Year Weathertightness

For specific details, please refer to the Warranty Guide at www.nucorbuildingystems.com.

Hard copies of all Nucor Building Systems warranties are available upon request.

Panel Options



Standard

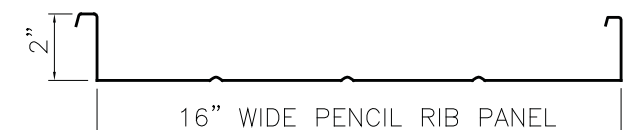

Optional

PANEL PROPERTIES

Engineering Properties of Nucor Building Systems 16" Nucor Vise Lock Seam Panel											
Designated Gage of Steel	Steel Yield KSI	Base Metal Thick. (In.)	Total Thick. (In.)	Panel Weight (lbs. / ft. ²)	Top In Compression			Bottom In Compression			Fb KSI
					Ix (In. ⁴ / ft.)	Sx (In. ³ / ft.)	Ma K-IN.	Ix (In. ⁴ / ft.)	Sx (In. ³ / ft.)	Ma K-IN.	
24 Ga.	50	0.0225	0.0241	1.35	0.166	0.099	2.97	0.073	0.061	1.83	30
22 Ga.	50	0.0300	0.0316	1.77	0.225	0.140	4.20	0.110	0.094	2.82	30
Gage of Panel	No. of Spans	Load Type	Maximum Total Uniform Load in PSF								
			Span Lengths, Ft.								
			1.50	2.00	2.50	3.00	3.50	4.00	4.50	5.00	
24 Ga.	1	POS	683	423	285	204	153	118	94	77	
	2	POS	460	276	183	129	96	74	59	48	
	3	POS	542	332	222	159	118	92	73	60	
	4	POS	516	314	210	149	111	86	68	56	
22 Ga.	1	POS	1042	629	417	296	220	170	135	110	
	2	POS	733	435	286	201	149	115	91	74	
	3	POS	873	527	350	248	185	143	113	92	
	4	POS	828	497	329	233	173	134	106	86	

Engineering Properties of Nucor Building Systems 16" Nucor Vise Lock 360 Seam Panel											
Designated Gage of Steel	Steel Yield KSI	Base Metal Thick. (In.)	Total Thick. (In.)	Panel Weight (lbs. / ft. ²)	Top In Compression			Bottom In Compression			Fb KSI
					Ix (In. ⁴ / ft.)	Sx (In. ³ / ft.)	Ma K-IN.	Ix (In. ⁴ / ft.)	Sx (In. ³ / ft.)	Ma K-IN.	
24 Ga.	50	0.0225	0.0241	1.35	0.140	0.078	2.34	0.063	0.056	1.68	30
22 Ga.	50	0.0300	0.0316	1.77	0.195	0.114	3.42	0.095	0.085	2.55	30
Gage of Panel	No. of Spans	Load Type	Maximum Total Uniform Load in PSF								
			Span Lengths, Ft.								
			1.50	2.00	2.50	3.00	3.50	4.00	4.50	5.00	
24 Ga.	1	POS	613	363	238	168	124	96	76	62	
	2	POS	450	264	172	121	90	69	55	44	
	3	POS	541	322	212	150	111	86	68	55	
	4	POS	512	303	199	140	104	80	64	52	
22 Ga.	1	POS	929	542	353	248	183	141	111	90	
	2	POS	700	407	264	185	137	105	83	68	
	3	POS	849	499	326	229	170	131	104	84	
	4	POS	801	469	306	215	159	122	97	79	

1. Panels were checked for bending, shear, combined bending and shear and deflection. Deflection was limited to span/150.
2. Section Properties have been calculated in accordance with the 2001 *North American Specification for the Design of Cold-Formed Steel Structural Members*.
3. Minimum yield strength of 24 and 22 gage steel is 50,000 psi.
4. Steel panels are either aluminum-zinc alloy or G-90 coated. The base metal thickness was used in determining section properties.
5. Positive load (POS) is applied inward toward the panel supports and is applied to the outer surface of the full panel cross-section.



NUCOR

BUILDING SYSTEMS

A Nucor Company

Indiana Plant

305 Industrial Parkway
Waterloo, IN 46793
Ph: 260-837-7891
Fax: 260-837-7384

Northeast Sales Office

201 Granite Drive
Suite 280
Lancaster, PA 17601
Ph: 717-735-7766
Fax: 717-735-7769

South Carolina Plant

P.O. Box 1006
200 Whetstone Rd.
Swansea, SC 29160
Ph: 803-568-2100
Fax: 803-568-2121

Texas Plant

600 Apache Trail
Terrell, TX 75160
Ph: 972-524-5407
Fax: 972-524-5417

Utah Plant

P.O. Box 907
1050 North Watery Lane
Brigham City, UT 84302
Ph: 435-919-3100
Fax: 435-919-3101

www.nucorbuildingsystems.com