

NUCOR BUILDING SYSTEMS WALL SHEETING ERECTION MANUAL

FOR FIELD USE

PLEASE DISTRIBUTE TO THE ERECTION CREW

WATERLOO, IN
305 Industrial Parkway
Waterloo, IN 46793
Phone: 260-837-7891
Fax: 260-837-7384

SWANSEA, SC
200 Whetstone Road
Swansea, SC 29160
Phone: 803-568-2100
Fax: 803-568-2121

TERRELL, TX
600 Apache Trail
Terrell, TX 75160
Phone: 972-524-5407
Fax: 972-524-5417

LANCASTER, PA
210 Granite Run Drive
Suite 280
Lancaster, PA 17601
Phone: 717-735-7766
Fax: 717-735-7769

BRIGHAM CITY, UT
1050 North Watery Lane
Brigham City, UT 84302
Phone: 435-919-3100
Fax: 435-919-3101

**DUE TO THE PROCESS OF CONTINUOUS IMPROVEMENT,
THE PRODUCTS AND PROCEDURES IN THIS MANUAL ARE
SUBJECT TO CHANGE WITHOUT NOTICE**

TABLE OF CONTENTS

1.0 TABLE OF CONTENTS

1.0 TABLE OF CONTENTS 2

1.0 RECEIVING, HANDLING, AND STORING MATERIALS 3

 1.1 Receiving Materials & Filing Claims 3

 1.2 Handling Materials 4

 1.3 Storing Materials 5

2.0 PANEL PROFILES 6

3.0 STANDARD PARTS 7

4.0 PROPER FASTENER INSTALLATION 9

5.0 PANEL PREPARATION 10

 5.1 Pre-Drilling Panels 10

 5.2 Important Information About Wall Panel Orientation 11

 5.3 Wall Panel Erection Notes 12

6.0 BASE TRIM INSTALLATION 13

 6.1 Standard Base Angle Trim 13

 6.2 Optional Base Trim 14

7.0 FASTENER REQUIREMENTS FOR EACH PANEL TYPE 15

 7.1 Fastener requirements for “CLASSIC” Wall Panel 15

 7.2 Fastener Requirements for “ACCENT” Wall Panel 16

 7.3 Fastener Requirements for “REVERSE CLASSIC” Wall Panel 17

 7.4 Proper Fastener Sequence Detail 18

8.0 FRAMED OPENING TRIM INSTALLATION 19

 8.1 Head Trim Preparation 19

 8.2 Head Trim Installation 20

 8.3 Standard Jamb Trim Installation 21

 8.4 “Reverse Classic” Panel Jamb Trim Installation 22

9.0 CORNER TRIM INSTALLATION 23

 9.1 “CLASSIC” Panel 23

 9.2 “ACCENT” Panel 24

 9.3 “REVERSE CLASSIC” Panel 25

TABLE OF CONTENTS

1.0 RECEIVING, HANDLING, AND STORING MATERIALS

that may result in a charge to **Nucor Building Systems**. Contact our **Service Representative** at:

1.1 RECEIVING MATERIALS & FILING CLAIMS

- Check shipment against delivery tickets during unloading.
- Note any damage or discrepancies on the delivery tickets before signing as receiver.
- **Nucor Building Systems** is not responsible for carrier damage or discrepancies not noted on the delivery tickets.
- The customer assumes full responsibility for the condition of this material after deliver by the trucking company.
- **Nucor Building Systems** is not responsible for items accepted in questionable condition.
- Upon acceptance of shipment(s), the **contractor** is responsible for the proper storage and handling of materials as described in this manual.
- **Nucor Building Systems** is not responsible for injury, damage, or loss as a result of improper storage and/or handling.
- All claims must be filed with **Nucor's Quality Services Representative** prior to any field modifications or purchases

WATERLOO, IN
305 Industrial Parkway
Waterloo, IN 46793
Phone: 260-837-7891
Fax: 260-837-7384

SWANSEA, SC
200 Whetstone Road
Swansea, SC 29160
Phone: 803-568-2100
Fax: 803-568-2121

TERRELL, TX
600 Apache Trail
Terrell, TX 75160
Phone: 972-524-5407
Fax: 972-524-5417

LANCASTER, PA
210 Granite Run Drive
Suite 280
Lancaster, PA 17601
Phone: 717-735-7766
Fax: 717-735-7769

BRIGHAM CITY, UT
1050 North Watery Lane
Brigham City, UT 84302
Phone: 435-919-3100
Fax: 435-919-3101

THIS BUILDING IS DESIGNED, MANUFACTURED, AND DELIVERED IN ACCORDANCE WITH THE **2006 M.B.M.A. METAL BUILDING SYSTEMS MANUAL**. CONSULT THE INFORMATION IN THE "COMMON INDUSTRY PRACTICES" SECTION.

TABLE OF CONTENTS

1.2 HANDLING MATERIALS

Nucor wall panels are rolled and banded, with a cover panel placed top and bottom.

Panel bundle weight can be found on i.d. tag at low end of each bundle. Maximum weight is 4300 pounds.

Bundles up to 25 feet can be handled using a forklift. Forks must be spaced a minimum of five feet apart.

Bundles over 25 feet should be handled with a crane using a spreader bar and nylon slings. Lifting should occur at center of gravity.

Locate slings at 1/4 of the length of the panel from each end of the bundle.

Trim crates/boxes are to be handled the same as panel bundles.

STEEL CHOKERS/SLINGS, CABLES OR CHAINS SHALL NOT BE USED.

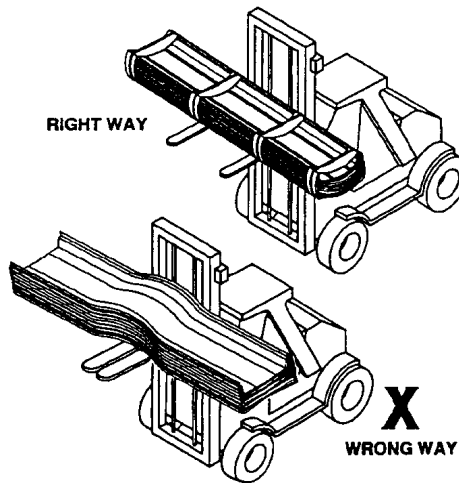
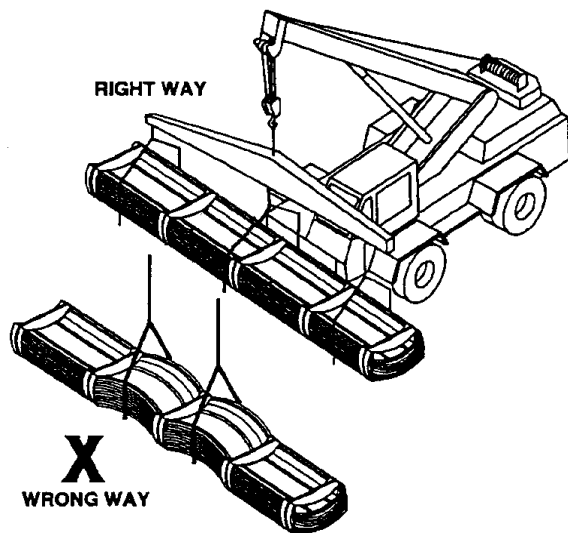

TABLE OF CONTENTS

1.3 STORING MATERIALS

Panel and trim bundles / crates should be blocked 12 inches above grade.

Elevate one end to allow moisture to drain.

Loosely cover with waterproof tarp to allow proper air circulation.

Inspect daily and dry if necessary.

Accessories must be kept dry and free of contamination. Store indoors if possible.

If the panels are wet, the bundles should be opened and then the panels should be dried and re-stacked to prevent damage.

IMPORTANT NOTE: The finish on these panels may not perform as intended if not erected within **90 days** from receipt at the job site. The finish is also subject to severe damage if moisture, debris, or dust is allowed to get between the panels; therefore, panels **MUST BE STORED UNDER COVER** with one end elevated to allow for drainage and protection against moisture, dust, or debris until erected. The manufacturer will not accept claims for non-performing panels if not properly stored at the jobsite. The customer assumes full responsibility for the condition of this material after deliver by the trucking company.

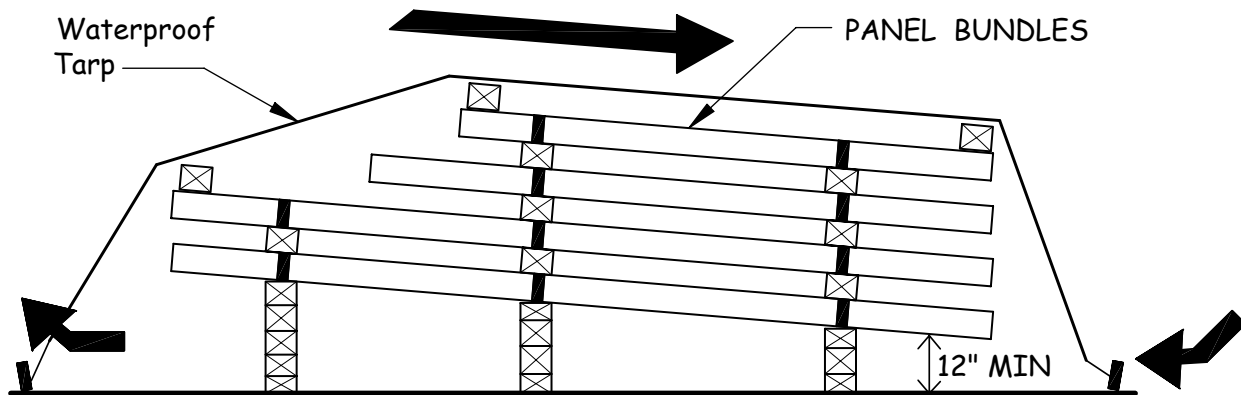
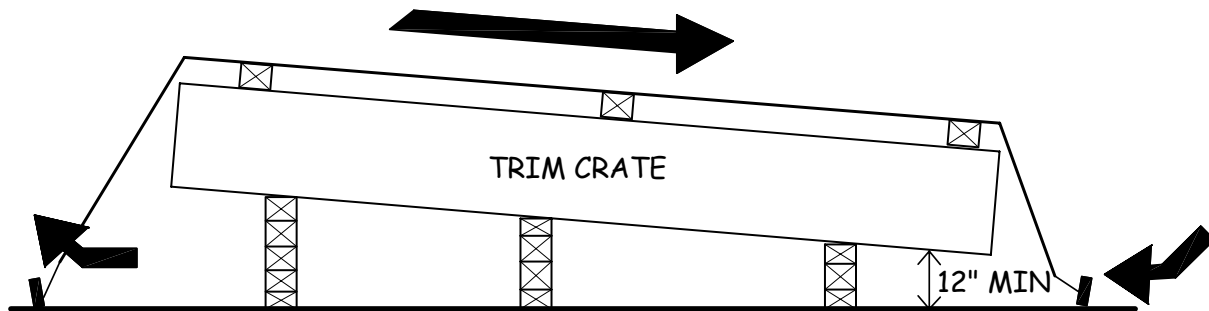

2.0 PANEL PROFILES

2.0 PANEL PROFILES

PART NUMBERING CONVENTIONS

Example: CW 6 - 12250

PANEL LENGTH (In Inches)
The last (2) digits are for fractions of an inch.

PANEL GAUGE
2 = 22 gauge
4 = 24 gauge
6 = 26 gauge

PANEL TYPE
CW = CLASSIC Panel
AW = ACCENT Panel
RC = REVERSE CLASSIC Panel

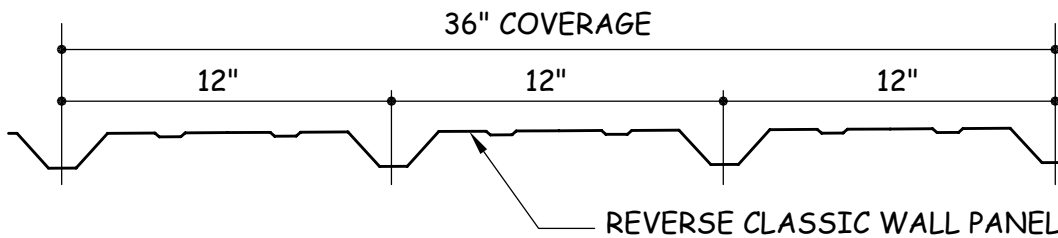
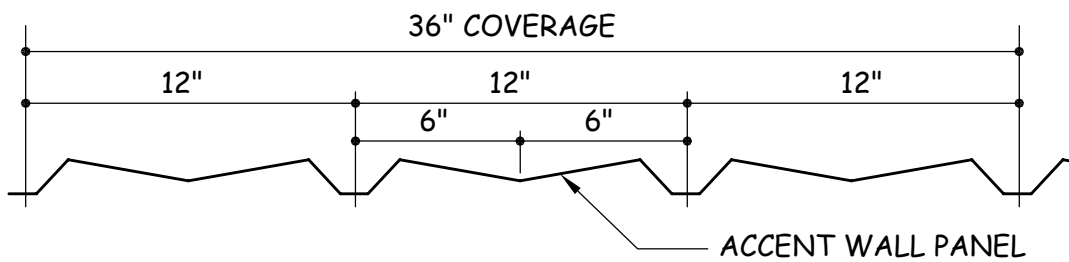
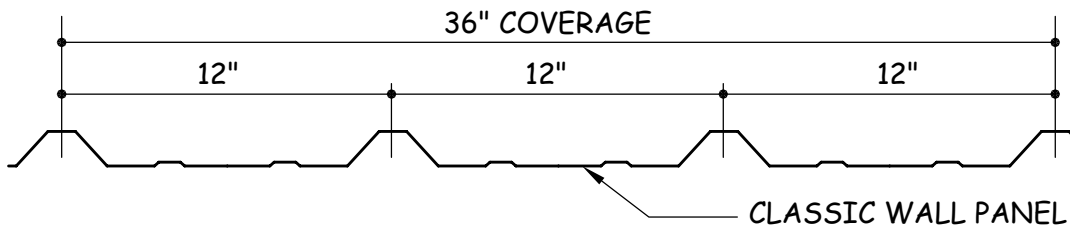

3.0 STANDARD PARTS

3.0 STANDARD PARTS

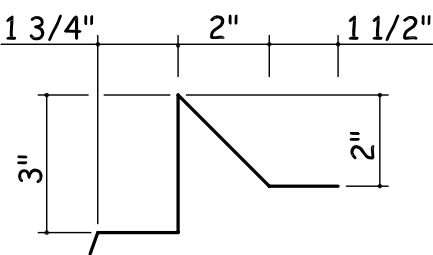
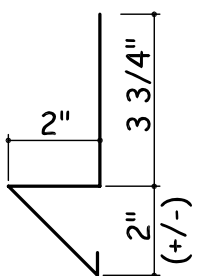
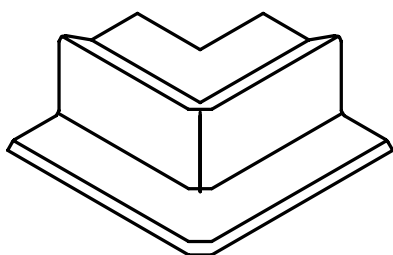
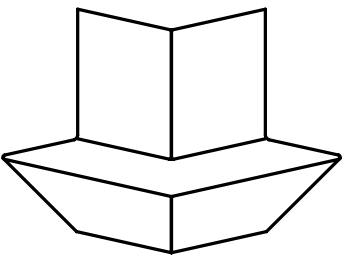
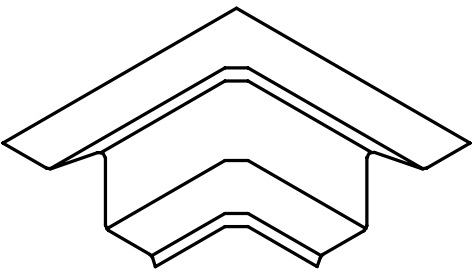
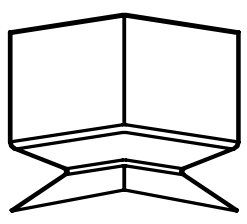
<p>STANDARD BASE TRIM</p> <p>18 Gauge Steel</p>  <p>Part Numbers BSA01 x 10'-1" BSA02 x 20'-2"</p>	<p>OPTIONAL BASE TRIM</p> <p>26 Gauge Steel</p>  <p>Part No. BSB01</p>
<p>PLASTIC OUTSIDE CORNER</p> <p>(For Standard Base Trim)</p>  <p>Part No. H4140</p>	<p>OUTSIDE CORNER</p> <p>(For Optional Base Trim)</p>  <p>Part No. H4200</p>
<p>PLASTIC INSIDE CORNER</p> <p>(For Standard Base Trim)</p>  <p>Part No. H4150</p>	<p>INSIDE CORNER</p> <p>(For Optional Base Trim)</p>  <p>Part No. H4210</p>

3.0 STANDARD PARTS

HEAD TRIM

26 Gauge Steel

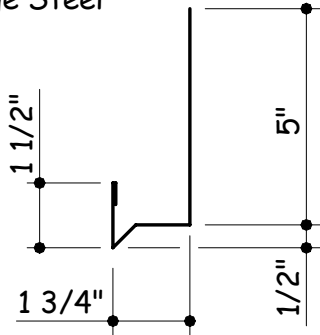

Part No. HTA__

JAMB TRIM

For Classic and Accent Panel

26 Gauge Steel

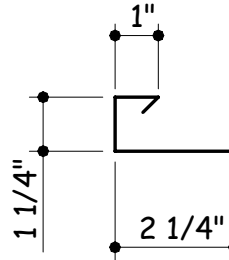

Part No. JTA__

JAMB TRIM

For Reverse Classic Panel

26 Gauge Steel

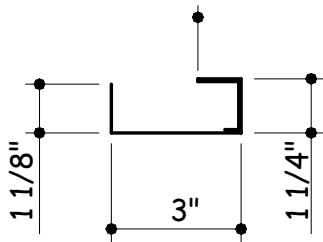

Part No. JTD__

SILL TRIM

26 Gauge Steel

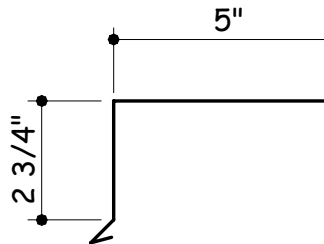

Part No. STA__

JAMB COVER TRIM

26 Gauge Steel

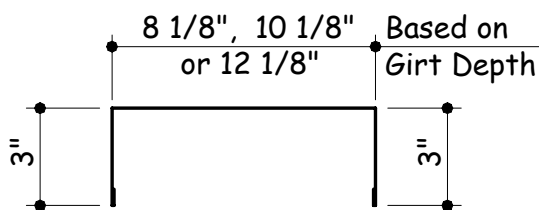

Part Numbers
 CCA01-8" Girts
 CCB01-10" Girts
 CCC01-12" Girts

PLASTIC DOOR END CLOSURE

(For Optional Base Trim at F. O.'s)
 Left and Right Part included as shown

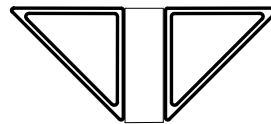

Part No. H4220

4.0 PROPER FASTENER INSTALLATION

4.0 PROPER FASTENER INSTALLATION

SEE THE FASTENER SCHEDULE BELOW

RECOMMENDED TOOL TYPES:

2000 - 2500 rpm screw gun with torque adjustable clutch

Manual or electric rivet tool

6-7 amp or higher rated tools (**DO NOT USE CORDLESS SCREW GUNS**)

DO NOT USE IMPACTING TOOLS

To assure proper voltage to the tool, extension cords should be checked for proper wire size/chord length.

16 gage wire, maximum chord length = **100'**

14 gage wire, maximum chord length = **200'**

12 gage wire, maximum chord length = **300'**

DRIVING TIPS:

Drive fasteners perpendicular to panel surface

Compress the insulation at fastener location with one hand while driving the fastener with the

other. This will help keep the panel flat and prevent the fastener from "walking".

Excessive pressure can cause drill point failure. Let the fastener do the work.



FIELD CUTTING OF PANELS:

When field cutting or mitering "Classic"TM wall panels, non-abrasive cutting tools such as nibblers or tin-snips shall be used. Abrasive cutting tools such as mechanical grinders, saws, shears, or scissors can damage the galvalume finish and create excess metal shavings that can corrode the panels. The use of non-approved cutting devices may void the factory warranty.

IMPORTANT NOTE: NOSE CONES SHOULD BE USED ON SCREW GUNS TO PREVENT DISTORTING THE PANEL AND TO HELP AVOID OVER-DRILLING THE FASTENERS.

FASTENER SEQUENCE

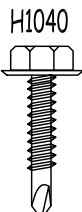
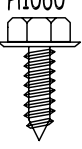
FASTENERS SHOULD BE INSTALLED FROM THE BASE TO THE EAVE. This will help prevent the panels from oil-canning. See section 7.4 for detail.

FASTENER	SPECIFICATIONS	USAGE
 <p>H1040</p>	<p>SELF-DRILLING SCREW No. 12-14x1 1/4" TEK 2 W/O Washer 5/16" HEAD Recommended Tool Types: -2000-2500 RPM; Torque Adjustable Clutch -DO NOT use Impacting Tools</p>	<p>Used attach wall panel, wall flashing and light gage parts. Maximum Insulation thickness is 6".</p>
 <p>H1060</p>	<p>SELF-TAPPING SCREW No. 12-14x 3/4" Sharp Point W/O Washer. 5/16" HEAD Recommended Tool Types: -2000 RPM; Torque Adjustable Clutch -DO NOT use Impacting Tools</p>	<p>Used to attach light gage wall trim end laps and trim to wall panels.</p>
 <p>H1100</p>	<p>POP RIVET 1/8" Blind Pop Rivet Recommended Tool Types: -Manual or Electric Rivet Tool -DO NOT use Impacting Tools</p>	<p>Used at trim laps, corner caps, and attaching lightgage material to siding where stitch screws can't be used.</p>

5.0 PANEL PREPARATION

5.0 PANEL PREPARATION

5.1 PRE-DRILLING PANELS

NUCOR RECOMMENDS PRE-DRILLING OF SIDELAP JOINTS, WHICH IN MANY CASES, WILL SPEED ERECTION AND MAKE A TIGHT JOINT.

STEP 1: Stack panels with ends flush on a level place on the ground in piles not exceeding 10 panels. Then place small wooden blocks under side lapping edge of stack of panels to hold them at correct height and position while drilling screw holes. Hold panels tightly together at each end with "Vise Grip Pliers". Carefully mark positions for sidelap fasteners on top of high rib. Fasteners should be located "ON CENTER" of high rib AS SHOWN BELOW.

STEP 2: Drill holes for "Stitch" screws (Use #1,-7/32"-15/64" drill-bit) on top sheet of sidelap. Be sure panels are well nested before drilling.

WHEN USING OTHER TYPE FASTENERS, SIZE OF DRILL-BIT MAY CHANGE!

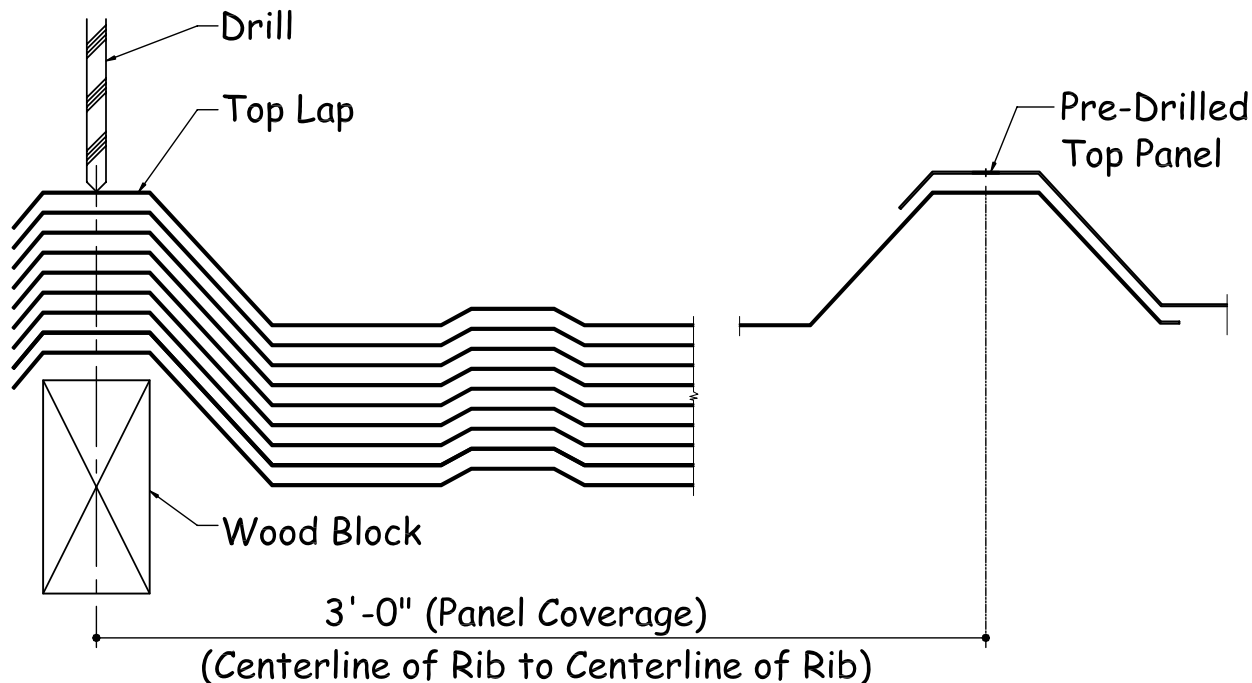

5.0 | PANEL PREPARATION

5.2 | IMPORTANT INFORMATION ABOUT WALL PANEL ORIENTATION

Nucor "ACCENT" and "REVERSE CLASSIC" wall panels are "HANDED" panels. The "UPTURNED" leg of the panel ALWAYS goes on the bottom. See the details below.

PANEL ERECTION →

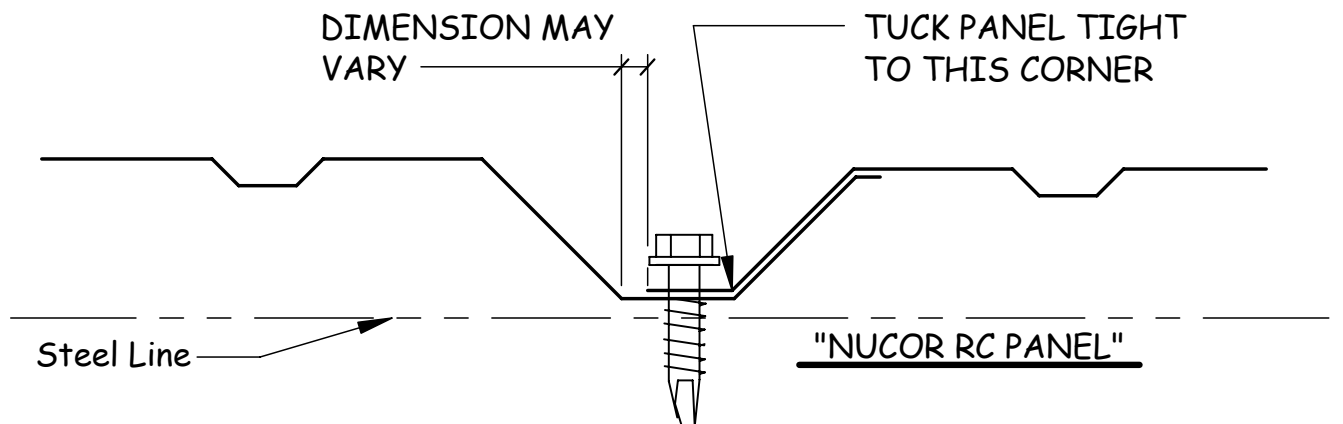
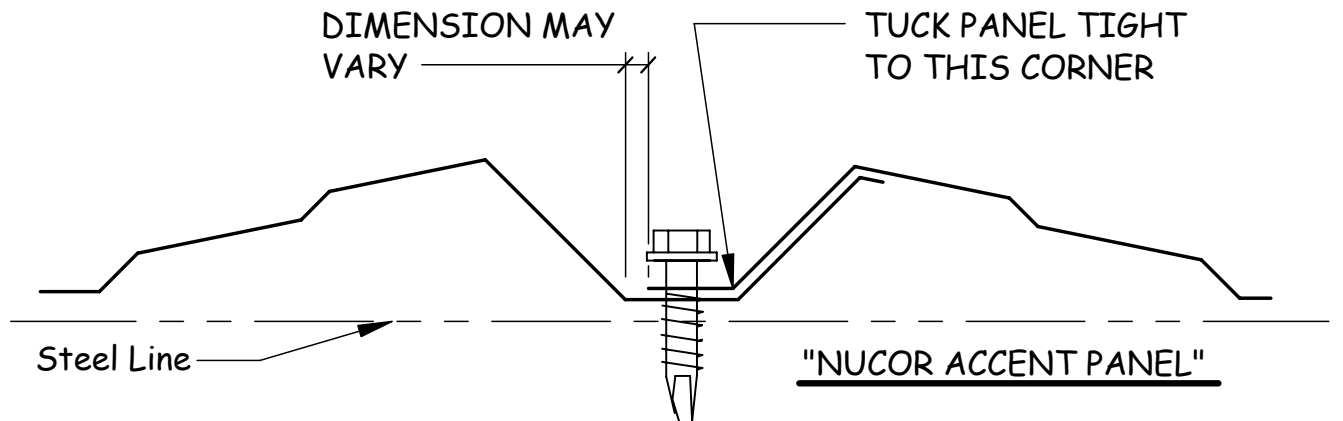
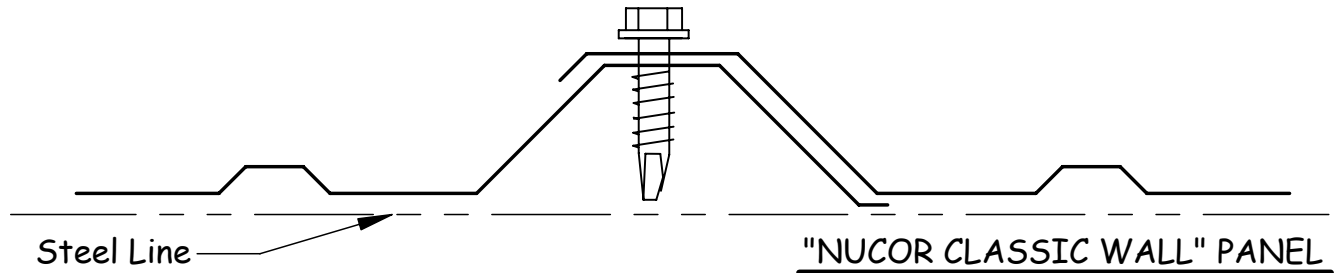

5.0 | **PANEL PREPARATION****5.3** | **WALL PANEL ERECTION NOTES**

- **Block girts to “level” position before starting panel erection.** Keep this blocking (blocking is not provided by NBS) in place until the wall panel to girt fasteners are installed.
- Make sure that the first wall panel is **aligned and plumb.**
- To prevent “Oil-Canning”, **all panel fasteners should start from the base** and then be fastened to each girt location working toward the eave
- Make sure that the foundation is **square, level, and correct** to the out-to-out steel line dimensions.
- The erection crew is responsible for **cleaning all wall panels** before leaving the job site.
- Prevailing wind, main traffic area, etc. should be taken into consideration when sheeting the wall.
- **Panels must be stored properly to prevent moisture damage.** Reference section **1.3** for additional information.

6.0 BASE TRIM INSTALLATION

6.0 BASE TRIM INSTALLATION

6.1 STANDARD BASE ANGLE TRIM

At Standard Base Angle Trim laps, apply a bead of **polyurethane tube caulk (H3152)** to all adjoining surfaces and lap 1".

INSULATION HINT: At the base, fold the insulation backer over the fiber to help prevent water from wicking.

See the erection drawing details for base trim corner termination parts numbers.

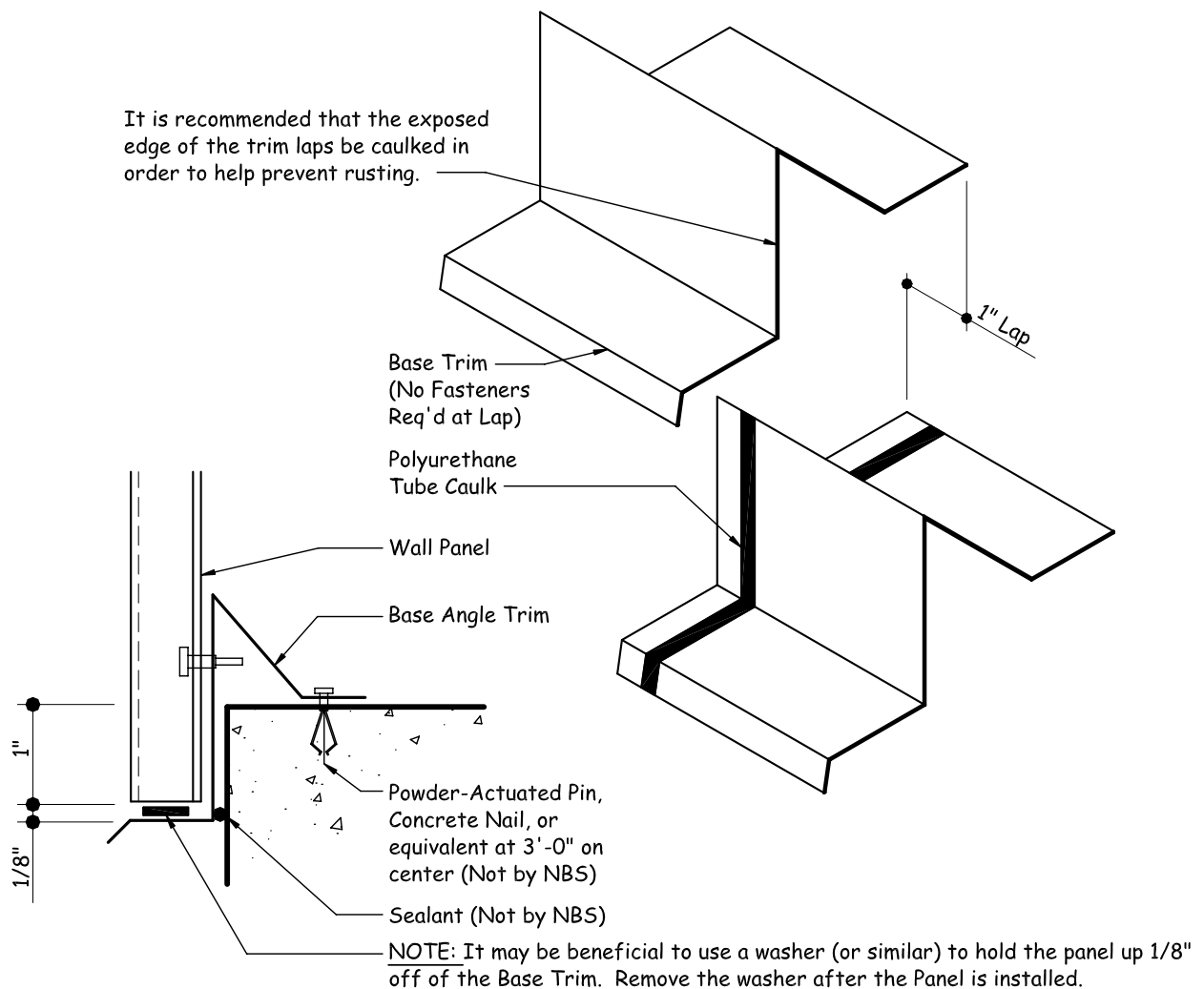

6.0 BASE TRIM INSTALLATION

6.2 OPTIONAL BASE TRIM

Before lapping trim, field cut the back vertical leg of the adjoining trim piece 1" as shown below. This will help to make the trim lap more readily.

At Optional Base Trim laps, apply a bead of **polyurethane tube caulk (H3152)** to all adjoining surfaces and lap 1".

See the erection drawing details for base trim corner termination parts numbers.

INSULATION HINT: At the base, fold the insulation backer over the fiber to help prevent water from wicking.

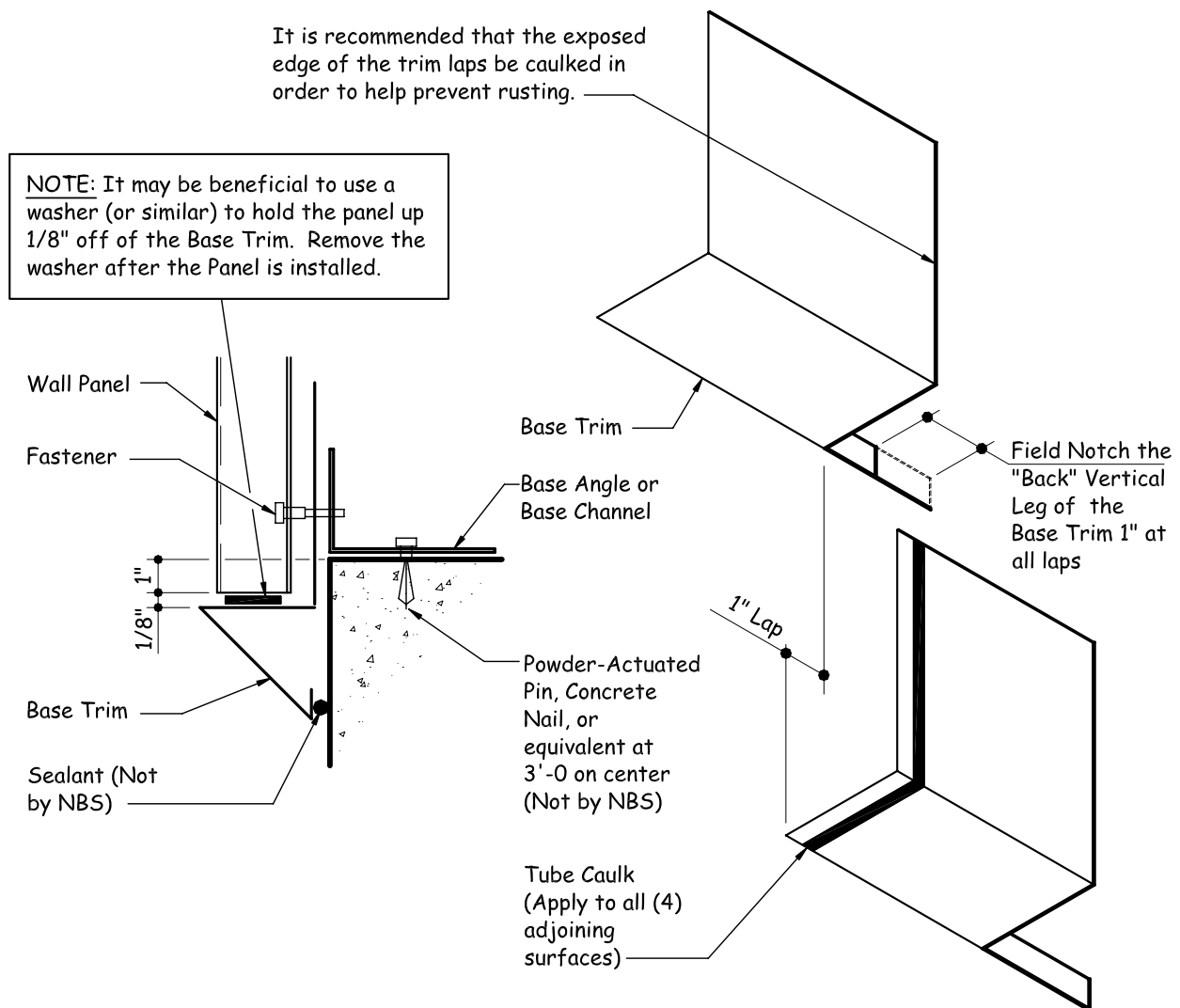

7.0 FASTENER REQUIREMENTS FOR EACH PANEL TYPE

7.0 FASTENER REQUIREMENTS FOR EACH PANEL TYPE

7.1 FASTENER REQUIREMENTS FOR "CLASSIC" WALL PANEL

NOTE: USE NOSE CONES ON SCREW GUNS TO PREVENT DISTORTING THE PANEL AND TO HELP AVOID OVER-DRIVING THE FASTENERS

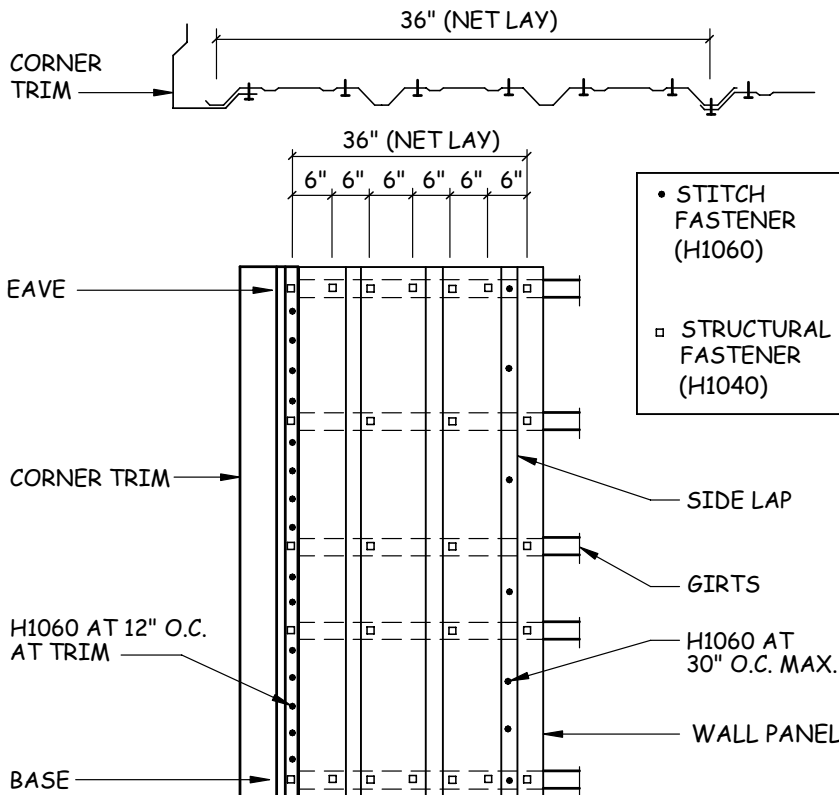

N.B.S. "CLASSIC WALL" ERECTION NOTES

ERECTOR NOTE: 1/2" SIDELAP MASTIC (H3010) IS REQ'D IN SNOWDRIFT CONDITIONS. REFER TO THE ELEVATIONS FOR LOCATION REQUIREMENTS.

CLASSIC PANEL

Fasten to base and eave structural members with 12-14 x 1 1/4" tek 2 structural fasteners (H1040) at 6" o.c. (next to each rib)

Fasteners to intermediate structural members with 12-14 x 1 1/4" tek 2 structural fasteners (H1040) at 12" o.c. (3" each side of rib)

Fasten sidelaps with 12-14 x 3/4" sharp point screws (H1060):
 - At girts
 - 30" o.c. between supports

Fasten trim with 12-14 x 3/4" sharp point screws (H1060) at 12" O.C.

7.0 FASTENER REQUIREMENTS FOR EACH PANEL TYPE

7.2 FASTENER REQUIREMENTS FOR "ACCENT" WALL PANEL

NOTE: USE NOSE CONES ON SCREW GUNS TO PREVENT DISTORTING THE PANEL AND TO HELP AVOID OVER-DRIVING THE FASTENERS

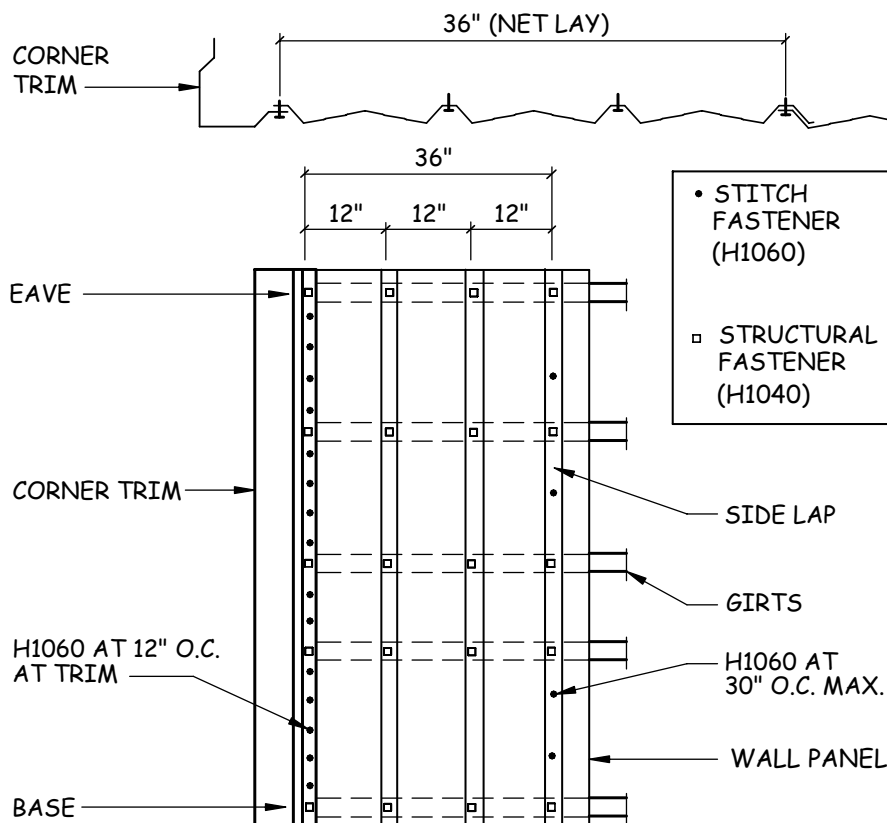

N.B.S. "ACCENT PANEL" ERECTION NOTES

ERECTOR NOTE: 1/2" SIDELAP MASTIC (H3010) IS REQ'D IN SNOWDRIFT CONDITIONS. REFER TO THE ELEVATIONS FOR LOCATION REQUIREMENTS.

ACCENT PANEL:

Fasten structural members with 12-14 x 1 1/4" tek 2 structural fasteners (H1040) at 12" o.c. (in each rib)

Fasten sidelaps with 12-14 x 3/4" sharp point screws (H1060):
 - At girts
 - 30" o.c. between supports

Fasten trim with 12-14 x 3/4" sharp point screws (H1060) at 12" O.C.

7.0 FASTENER REQUIREMENTS FOR EACH PANEL TYPE

7.3 FASTENER REQUIREMENTS FOR "REVERSE CLASSIC" WALL PANEL

NOTE: USE NOSE CONES ON SCREW GUNS TO PREVENT DISTORTING THE PANEL AND TO HELP AVOID OVER-DRIVING THE FASTENERS

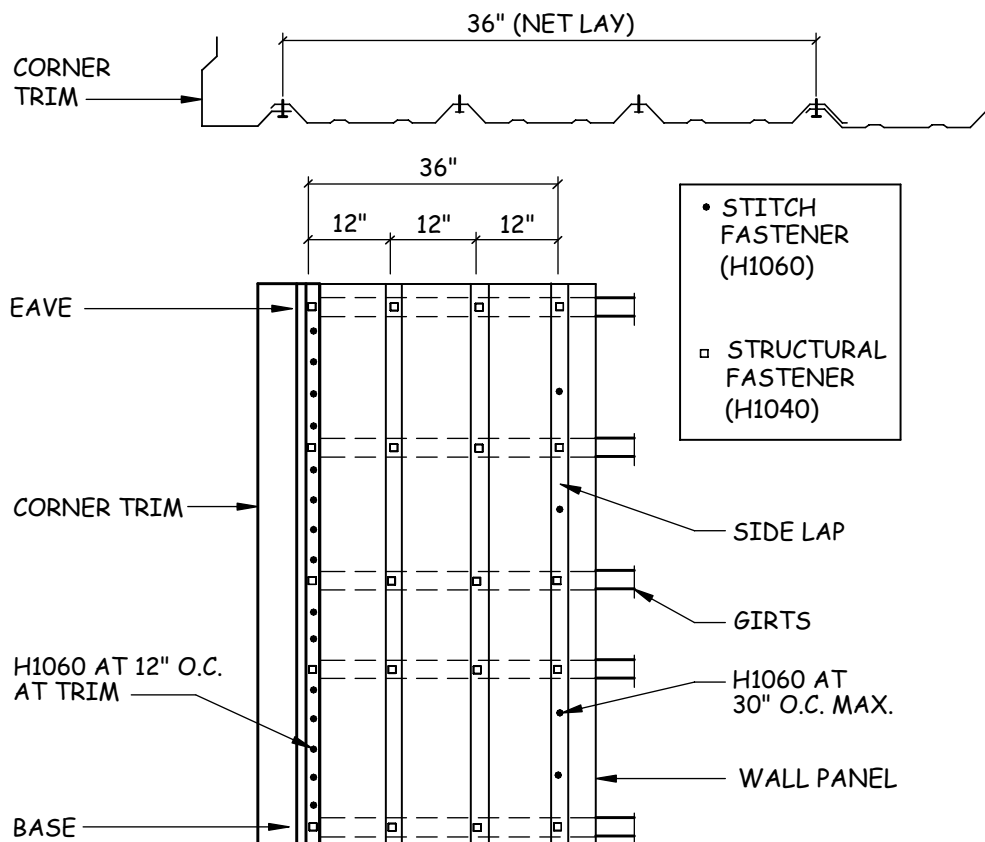

N.B.S. REVERSE "CLASSIC WALL" ERECTION NOTES

ERECTOR NOTE: 1/2" SIDELAP MASTIC (H3010) IS REQ'D IN SNOWDRIFT CONDITIONS. REFER TO THE ELEVATIONS FOR LOCATION REQUIREMENTS.

REVERSE CLASSIC PANEL:

Fasten structural members with 12-14 x 1 1/4" tek 2 structural fasteners (H1040) at 12" o.c. (in each rib)

Fasten sidelaps with 12-14 x 3/4" sharp point screws (H1060):
 - At girts
 - 30" o.c. between supports

Fasten trim with 12-14 x 3/4" sharp point (H1060) screws at 12" o.c.

7.0 FASTENER REQUIREMENTS FOR EACH PANEL TYPE

7.4 PROPER FASTENER SEQUENCE DETAIL

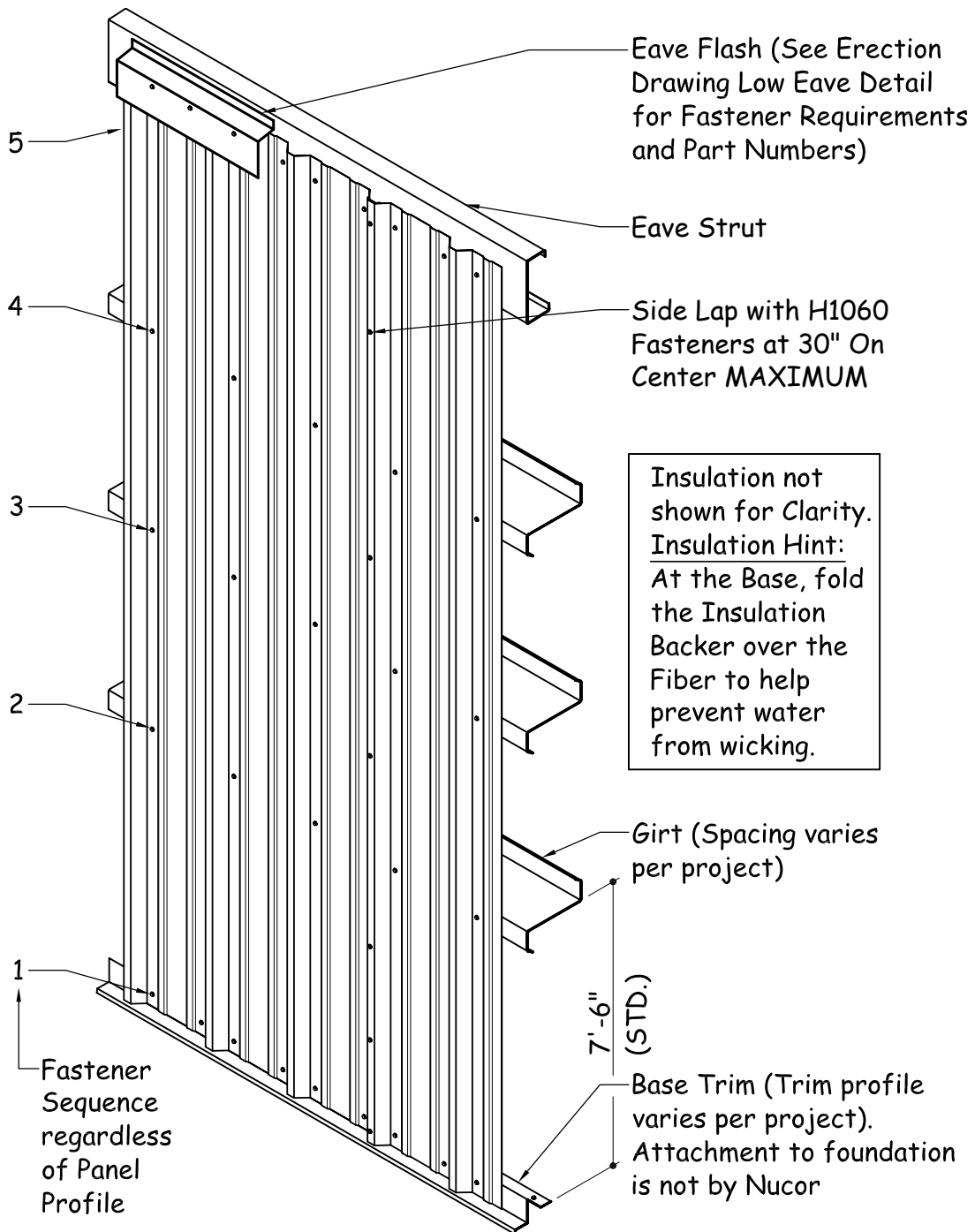

NOTE: "CLASSIC" Profile shown. Refer to Sections 7.2 and 7.3 for Fastener quantity requirements for "ACCENT" and "REVERSE CLASSIC" profiles.

8.0

FRAMED OPENING TRIM INSTALLATION

8.0 FRAMED OPENING TRIM INSTALLATION

8.1 HEAD TRIM PREPARATION

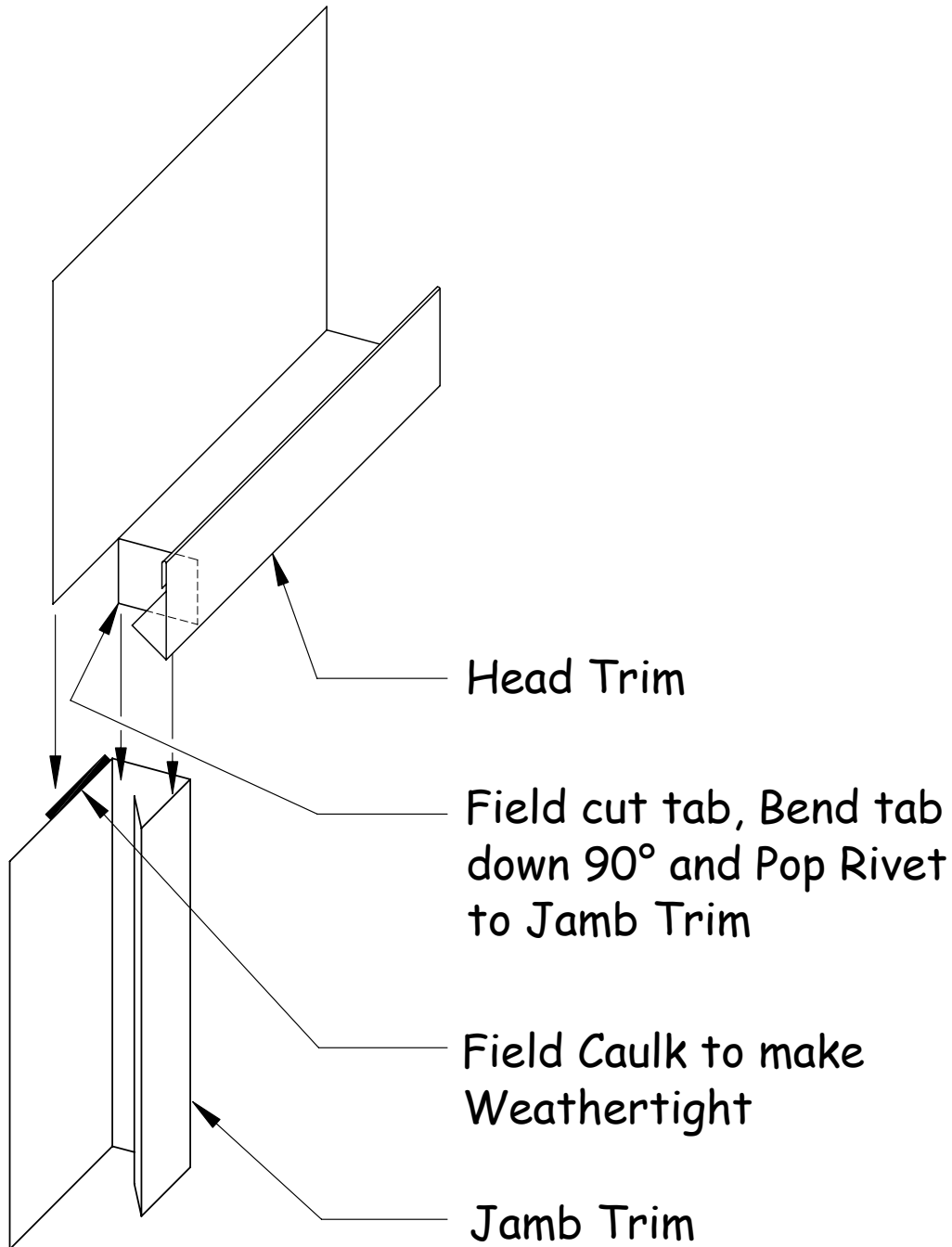

8.0 FRAMED OPENING TRIM INSTALLATION

8.2 HEAD TRIM INSTALLATION

Slide the head trim into place and fasten at each end and 12" on center with panel colored **self-drilling screws (H1040)**. See the erection

drawing sheeting elevations for head trim mark numbers.

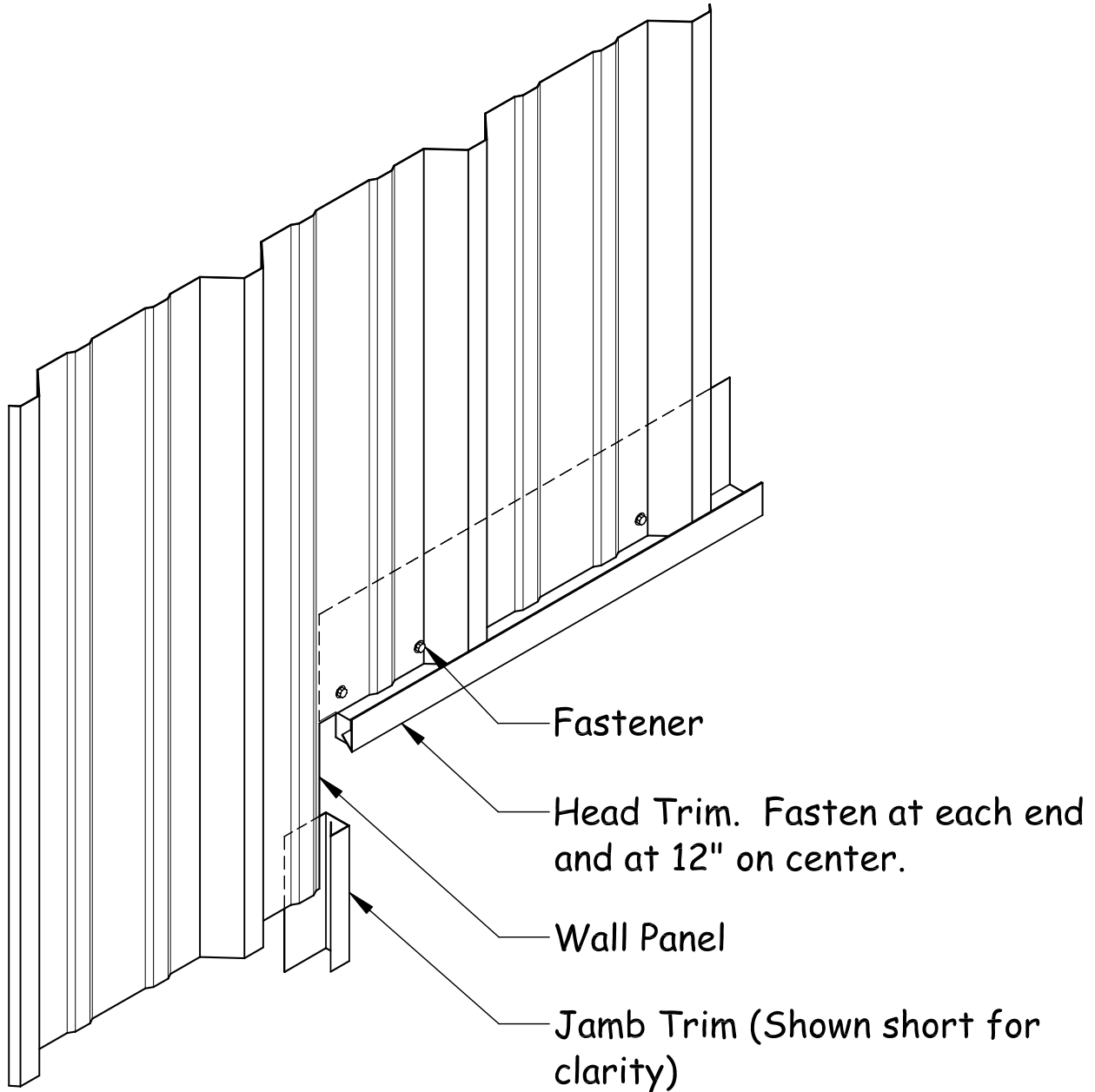

8.0 FRAMED OPENING TRIM INSTALLATION

8.3 STANDARD JAMB TRIM INSTALLATION

Install the jamb trim after the head trim is installed. Fasten with panel colored **self-drilling screws (H1040)** at 12" on center. See the

erection drawing sheeting elevations for jamb trim mark numbers.

NOTE: The Top end of the Jamb Trim should butt against the Head Trim. **ALSO:** Be sure to install the Base Trim Plastic End Caps at Framed Openings (If your project utilizes Base Trim mark number BSB01).

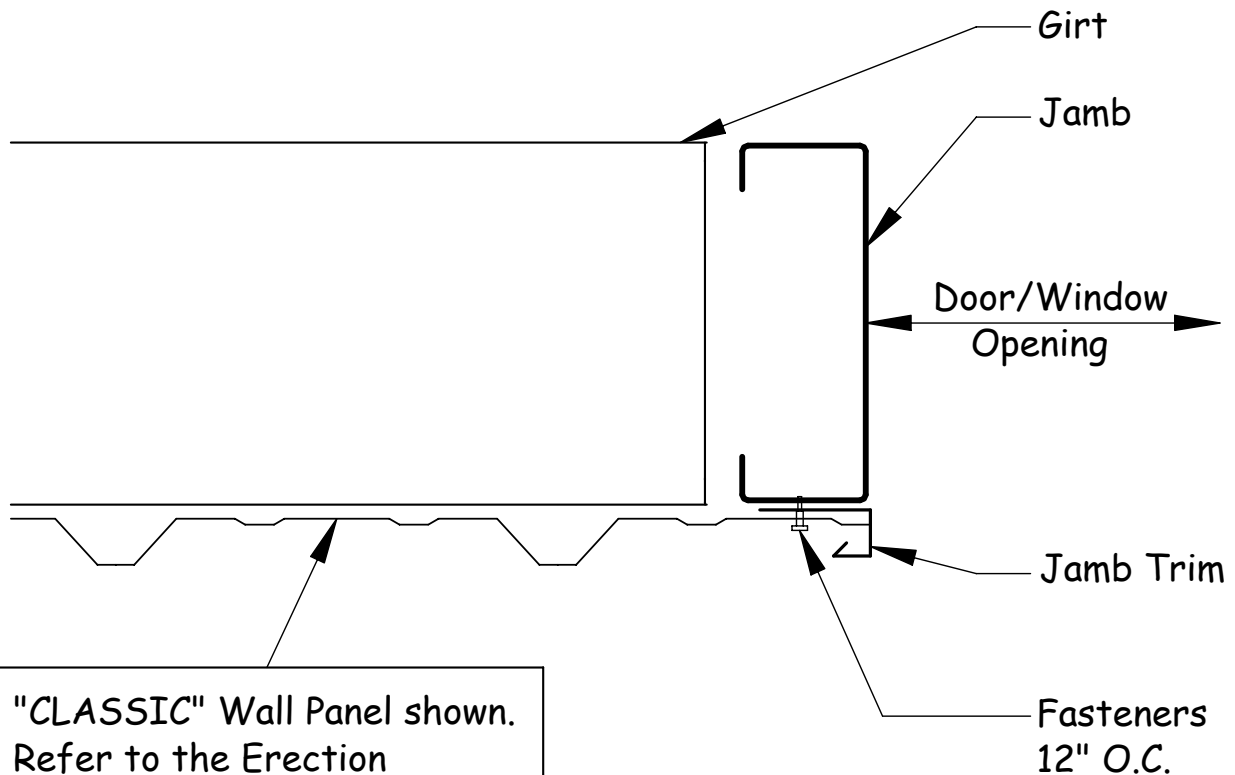

8.0 FRAMED OPENING TRIM INSTALLATION

8.4 "REVERSE CLASSIC" PANEL JAMB TRIM INSTALLATION

installing the wall panel adjacent to the framed opening. This applies to both the "STANDARD" and "ALTERNATE" details below.

Install the Jamb Trim (See Erection Drawing Sheeting Elevations for Part Numbers) with **self-drilling screws (H1040)** at 12" on center **before**

STANDARD DETAIL AT PANEL FLAT

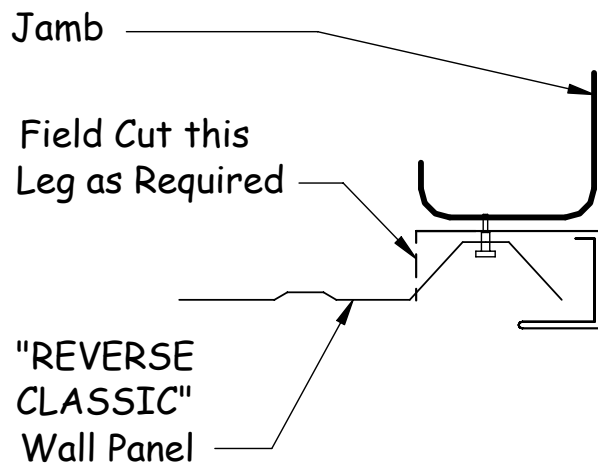
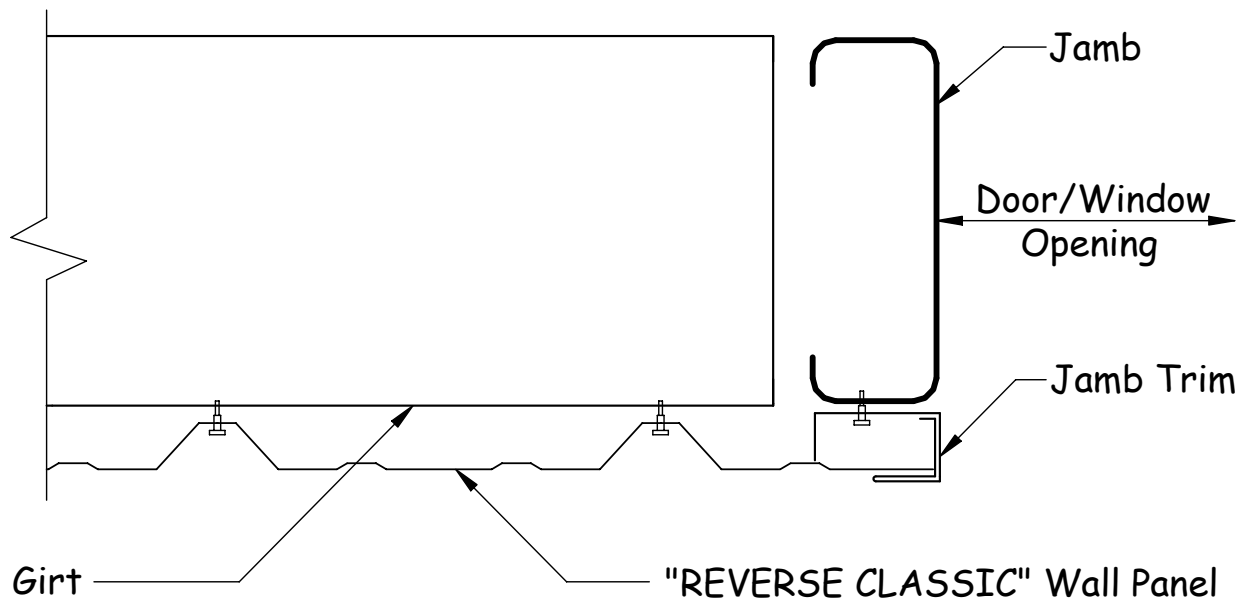

ALTERNATE DETAIL AT PANEL RIB

NOTE: If the Framed Opening is located at a Panel Rib, Use this Detail. The Jamb Trim will need to be field modified as shown.

9.0 CORNER TRIM INSTALLATION

9.0 CORNER TRIM INSTALLATION

9.1 "CLASSIC" PANEL

"CLASSIC" PANEL OUTSIDE CORNER DETAIL

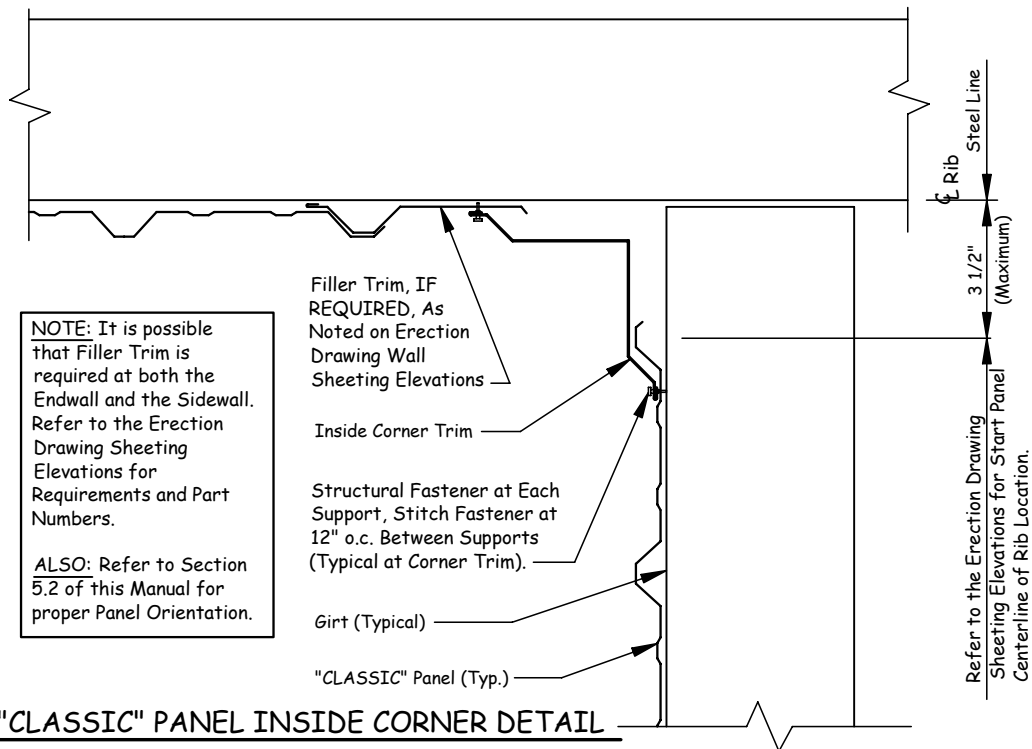
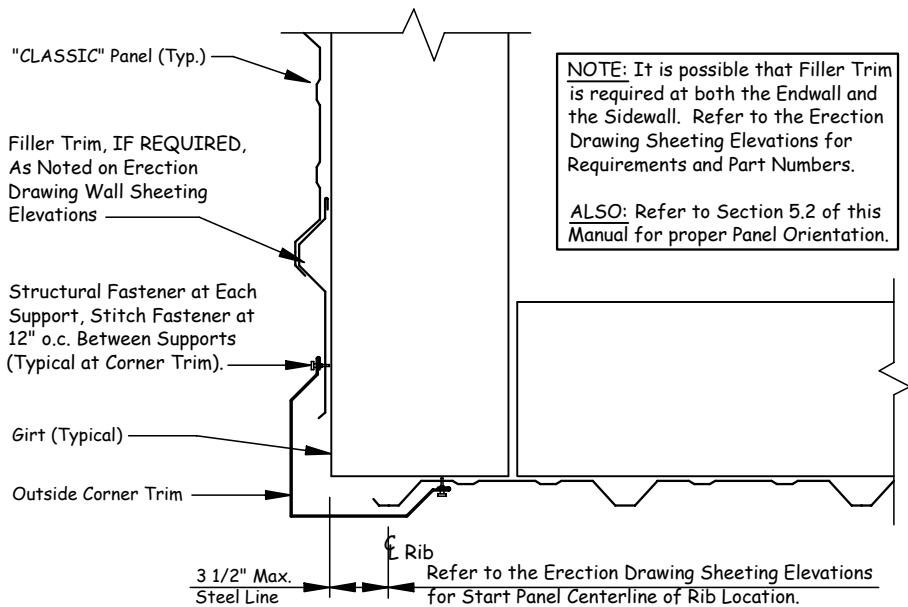

"CLASSIC" PANEL INSIDE CORNER DETAIL

9.0 CORNER TRIM INSTALLATION

9.2 "ACCENT" PANEL

"ACCENT" PANEL OUTSIDE CORNER DETAIL

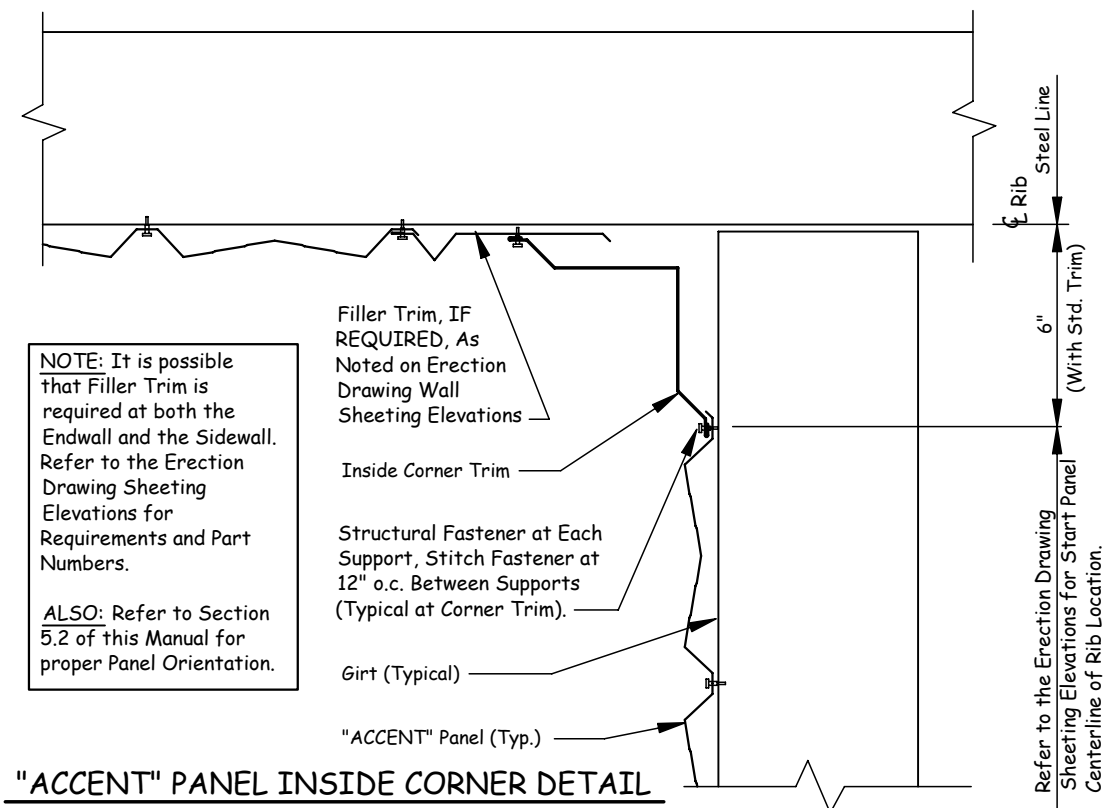
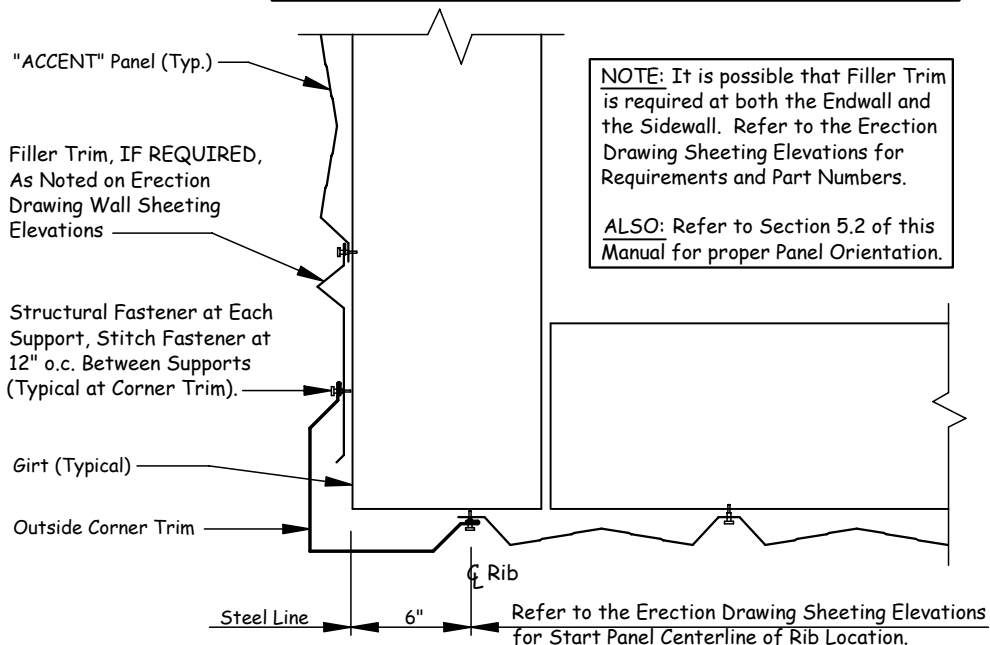

9.0 CORNER TRIM INSTALLATION

9.3 "REVERSE CLASSIC" PANEL

"REVERSE CLASSIC" PANEL OUTSIDE CORNER DETAIL

